



BubbleSpa®

Air-Powered Shower Technology



BubbleSpa with Wall Arm
BubbleSpa with Ceiling Arm

95001000
95002000



We at Kelda Showers are the inventors of Air Powered technology. Our patented technology delivers showers which provide elegant experience whilst using low amounts of water. Kelda showers are not only eco-friendly, but they are engineered to last too. They have been exposed and tested in the most demanding real-life environments to ensure they can withstand the pressures of high usage.

Kelda Showers is thrilled to introduce the World's first BubbleSpa® shower. At the forefront of luxury showering, Kelda is injecting magic into the showering experience to transform the everyday bathroom into a place of personal sanctuary and tranquility. Kelda's unique BubbleRain spray form creates very large droplets filled with air that fall softly on the body for a luxurious shower feel that revitalises the skin and rinses away stress.

Kelda BubbleSpa® designed in the UK. Enjoy a magical shower experience every time.

You can find more information on our website:
[www. https://www.keldashowers.com](https://www.keldashowers.com)

Table of Contents

- 3 - Important Safety Information
- 4 - System Diagram
- 8 - Contents
- 10 - Installation
- 18 - Electrical Installation
- 20 - User Guide
- 22 - Maintenance
- 26 - Troubleshooting
- 27 - Customer Care



Important Safety Information

This product requires a hot and a cold water supply in addition to an electrical connection (see Electrical section on pages 18 - 19 for details). This product is not an electric shower.

Products manufactured by Kelda Technology are safe and without risk provided they are installed, used and maintained in accordance with our instructions and recommendations.

DO NOT operate the unit if the showerhead becomes damaged.
DO NOT restrict flow out of shower by placing an obstruction in front of the showerhead nozzles.

DO NOT allow children to play with the shower

DO NOT allow children to use the shower without supervision

General

1. Read all of these instructions before installation and retain them for later use.
2. DO NOT take risks with plumbing or electrical equipment.
3. Isolate electrical and water supplies before proceeding with the installation.
4. The showerhead must be cleaned regularly with descalant to remove scale and debris (see Maintenance section on page 22).
5. This product is not suitable for mounting into steam rooms or steam cubicles.
6. The shower should not be installed in an outdoor environment, including sheltered areas.
7. DO NOT spray water at the BubbleSpa showerhead as this risks damaging the electronics.

Plumbing

1. The plumbing installation must comply with water regulations, building regulations or any particular regulations as specified by local water company or water undertakers and should be in accordance with BS EN 806 (Specifications for installations inside buildings conveying water for human consumption. Operation and maintenance).
2. **IMPORTANT! The hot and cold-water supply pipes must be flushed to clear debris from before connecting to water inlets on the shower.**
3. DO NOT use excessive force when making connections to the mixer.
4. All plumbing connections must be completed before making the electrical connections.
5. **Water Pressure:** A 1.5 bar mixed supply is required as a minimum at the valve output, if using a low pressure (Gravity fed) system a suitable pump will be required. Your BubbleSpa shower is designed to perform best between 8-10L/min and will not produce bubbles with a flow rate below 6L/min. Using the BubbleSpa shower without a Kelda

supplied flow regulator will void the warranty and negatively affect the performance of the product.

Electrical

1. The installation must comply with BS 7671 'Requirements for electrical installations' (IEE wiring regulations), building regulations or any particular regulations as specified by the local electrical supply company.
2. In accordance with 'The Plugs and Sockets etc. (Safety) Regulations 1994', this appliance is intended to be permanently connected to the fixed wiring of the electrical mains system.
3. A 32A 30 mA Residual Current Breaker Operator (RCBO) MUST be installed in all UK electric and pumped shower circuits. This may be part of the consumer unit or a separate unit.
4. Each shower must be connected to a 3A switched fused spur which is easily accessible. Switch off at fused spur for maintenance or if not in use for extended periods. This is a safety procedure recommended with all electrical appliances.
5. Make sure all electrical connections are tight to prevent overheating.
6. As with all electrical appliances it is recommended to have the shower and installation checked at least every two years by a competent electrician to ensure there is no deterioration due to age and usage.

Flashing Lights

To enhance the visual impact of the bubbles this shower uses flashing light effects, with a minimum frequency of 72Hz. This is in accordance with safety guidance from the IEE (IEE 1789-2015) and is safely above the 3-30Hz range (commonly identified as values to be avoided for people with photosensitive conditions).

The visual effect of the lighting modes will vary depending on ambient lighting and the environment in which it is installed (see page 21 for more details on Bubble Modes).

Anyone diagnosed with a condition which could be triggered by flashing lights should seek further medical advice.

System Diagram

BubbleSpa Wall Arm

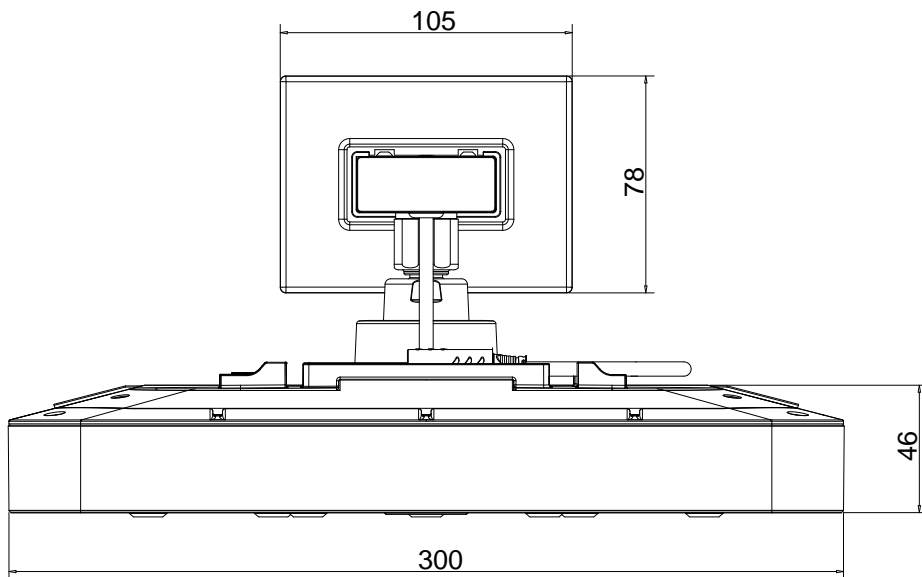
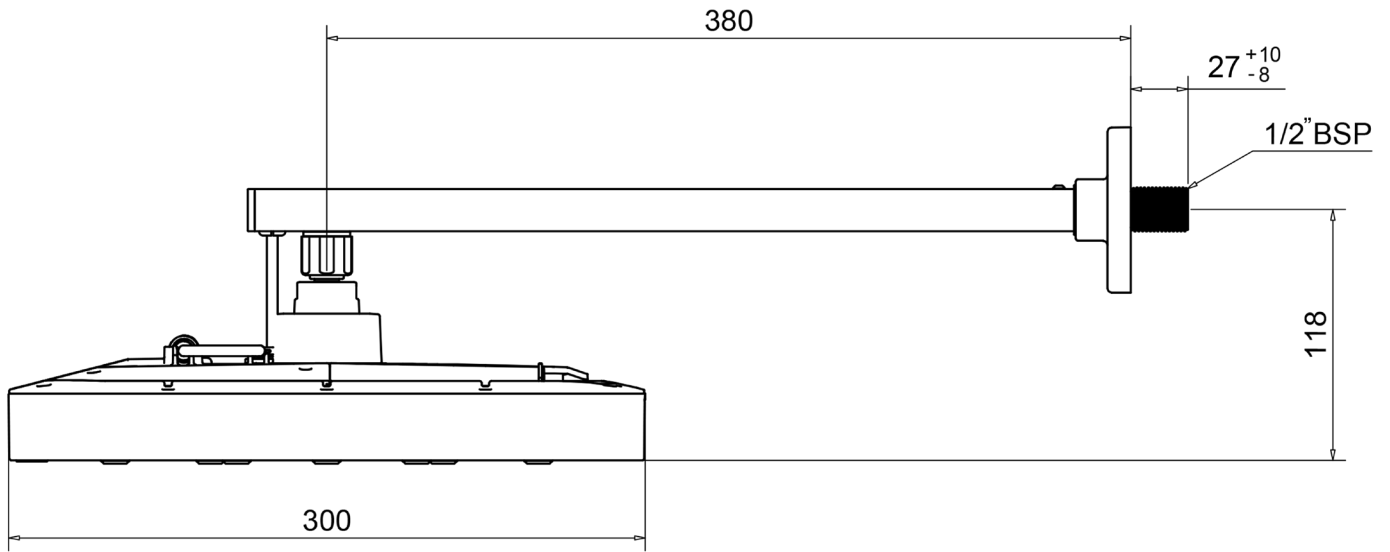

10° Max tilt
of Ball Joint

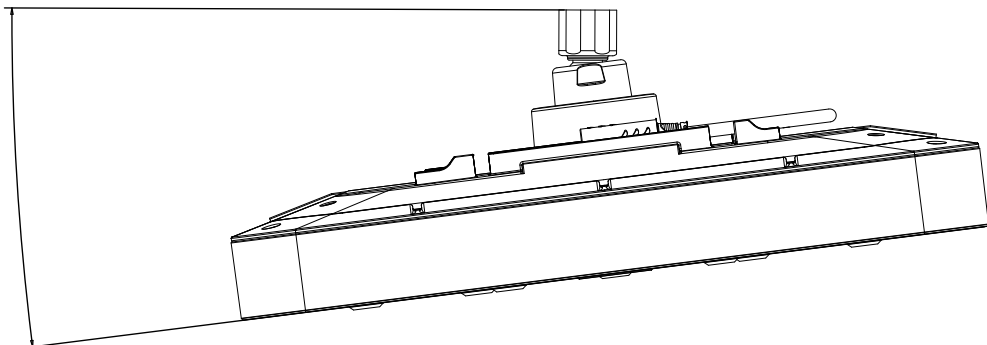

Tilting of the BubbleSpa showerhead can be in any direction. All dimensions are in mm unless otherwise stated.

System Diagram

BubbleSpa Wall Arm & Valve

| No. | Part | Qty |
|-----|----------------------|-----|
| 1 | Wall Arm Extrusion | 1 |
| 2 | Water Path Connector | 1 |
| 3 | Wall Screws | 4 |
| 4 | Wall Plugs | 4 |
| 5 | BubbleSpa Showerhead | 1 |

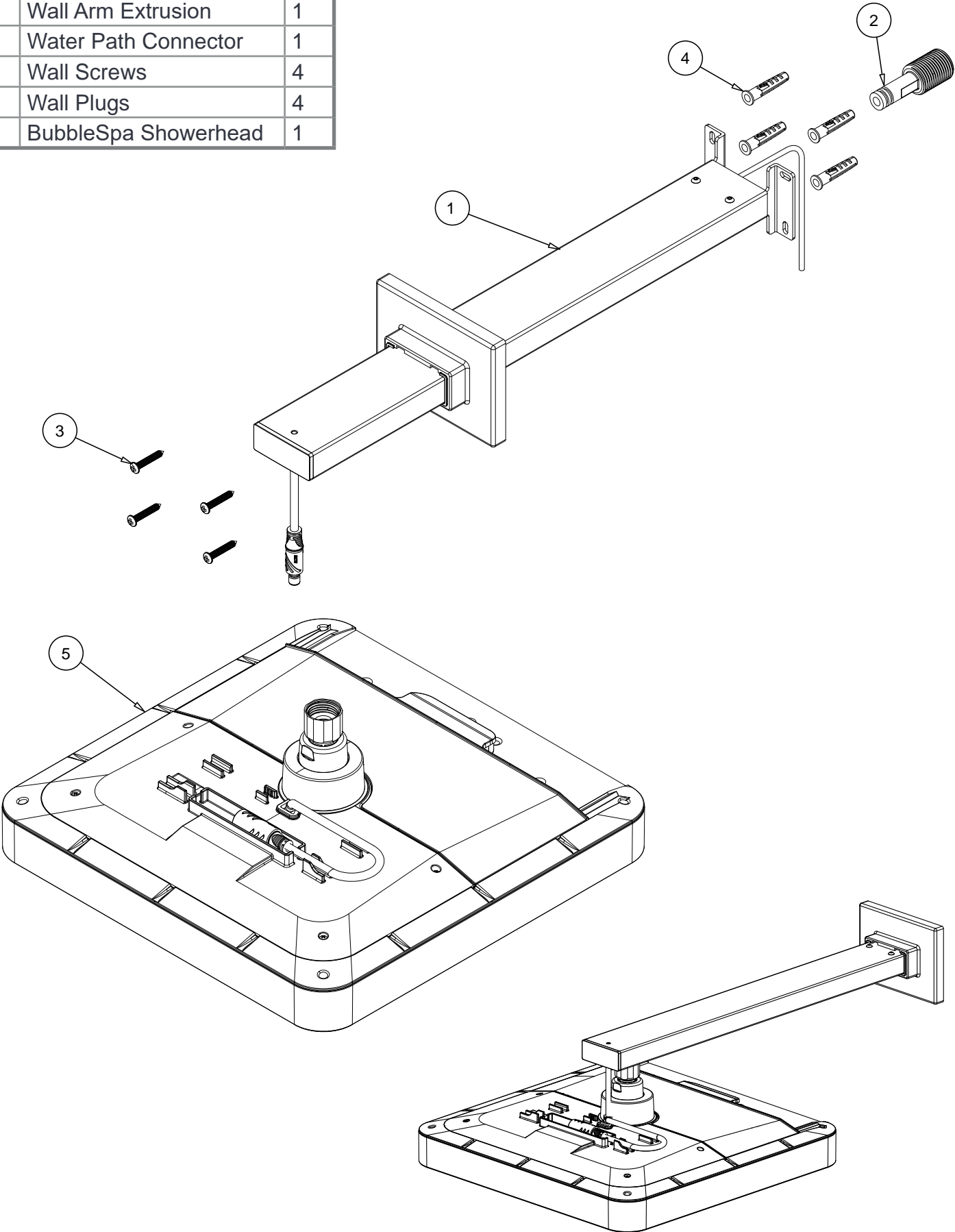

System Diagram

BubbleSpa Ceiling Arm

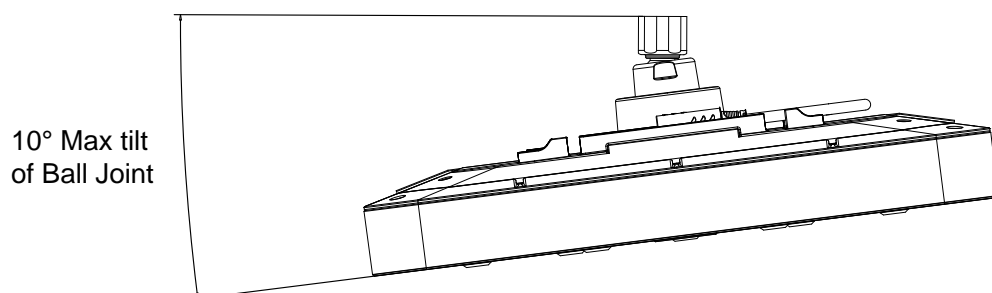
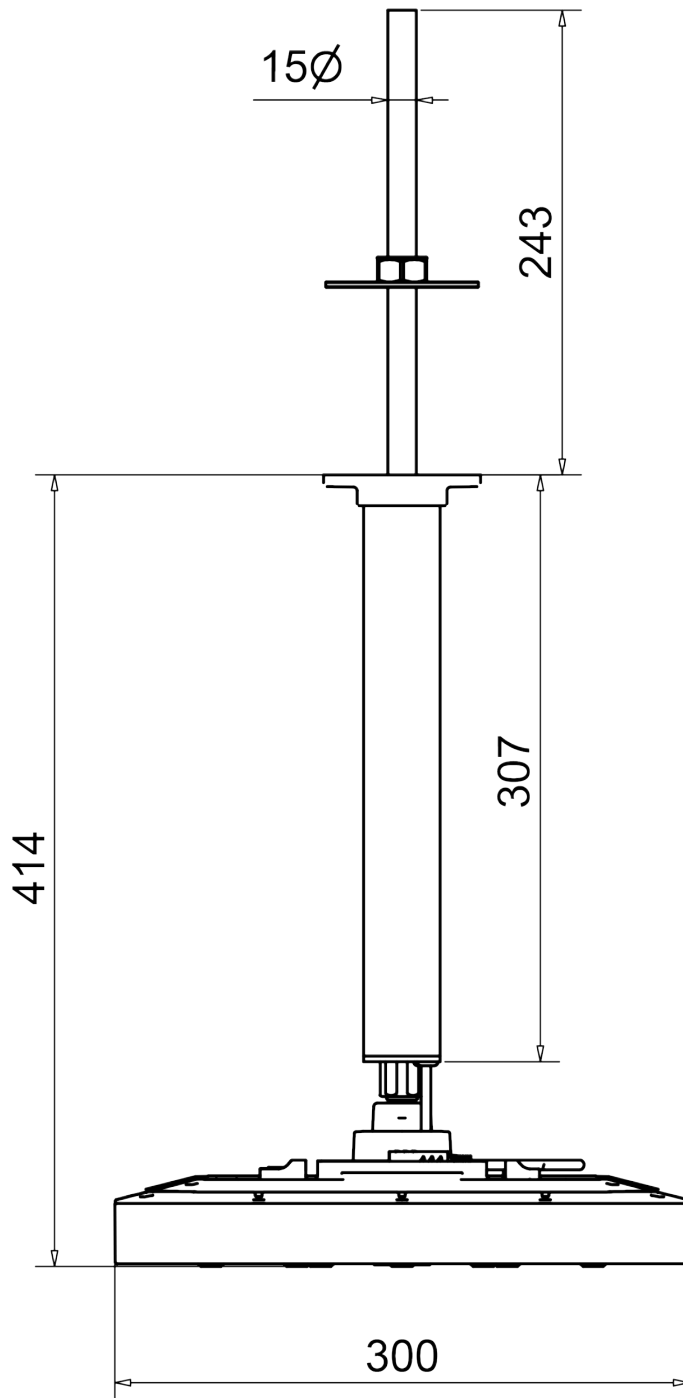

**Drawing shows the lengths of the parts as supplied. The Inner Pipe can be cut down to an appropriate length if necessary. The tilting of the BubbleSpa showerhead can be in any direction. All dimensions are in mm unless otherwise stated.*

System Diagram

BubbleSpa Ceiling Arm & Valve

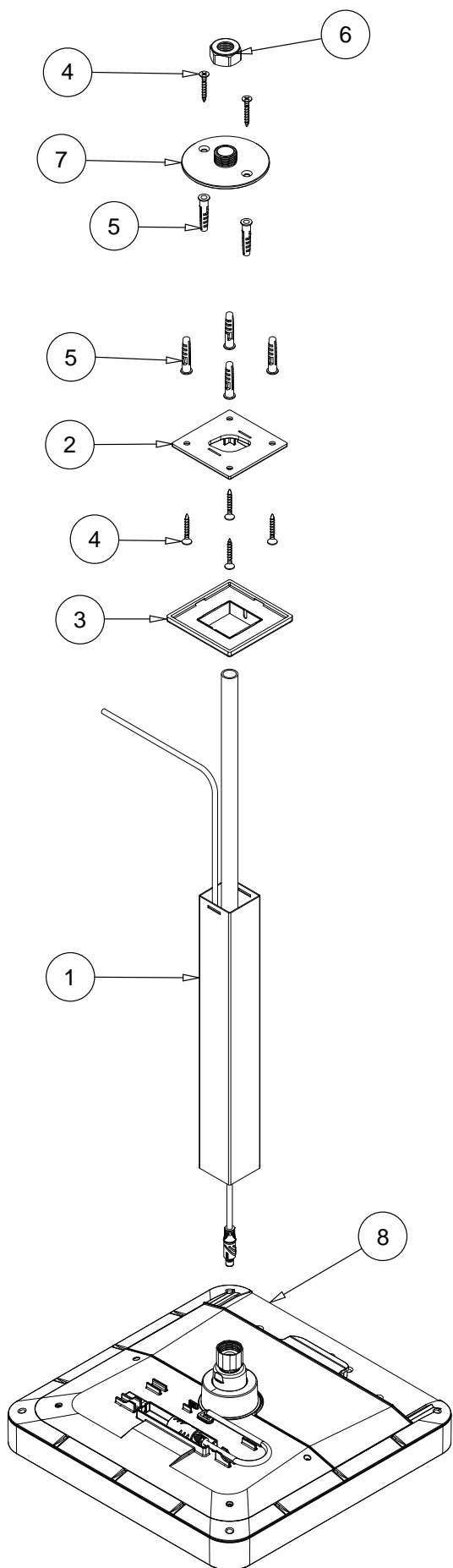

| No. | Part | Qty |
|-----|-----------------------|-----|
| 1 | Ceiling Arm Extrusion | 1 |
| 2 | Ceiling Arm Bracket | 1 |
| 3 | Ceiling Arm Trim | 1 |
| 4 | Wall Screws | 6 |
| 5 | Wall Plugs | 6 |
| 6 | 1/2" BSP Nut | 1 |
| 7 | Mounting Plate | 1 |
| 8 | BubbleSpa Showerhead | 1 |

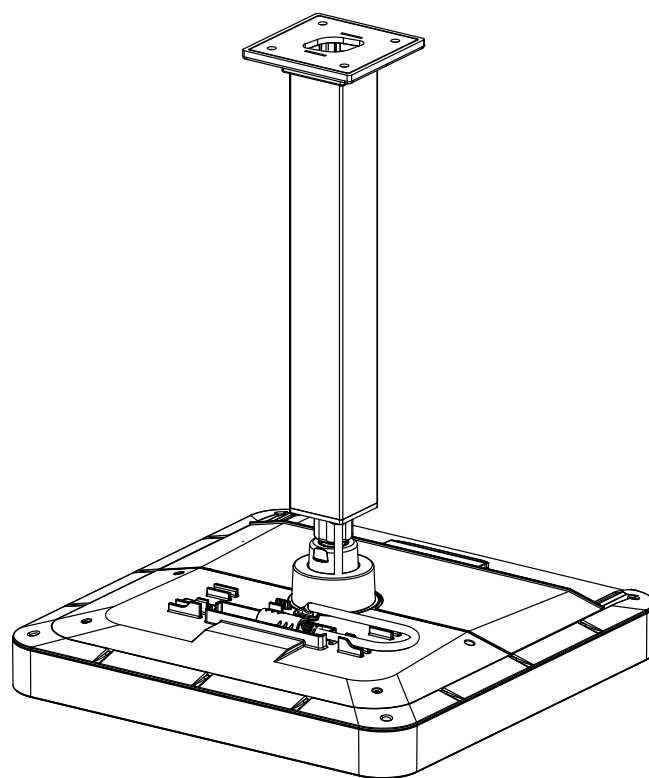

Contents

BubbleSpa Wall Arm

Your BubbleSpa shower includes the following assemblies and parts:

1 Showerhead

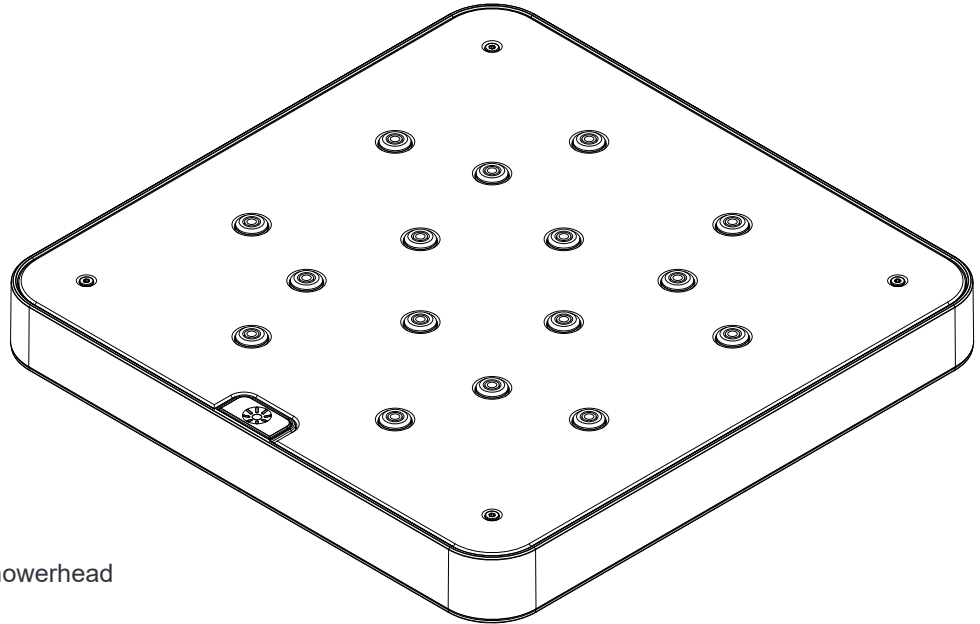

- x1 Kelda BubbleSpa Showerhead

2 Wall Arm

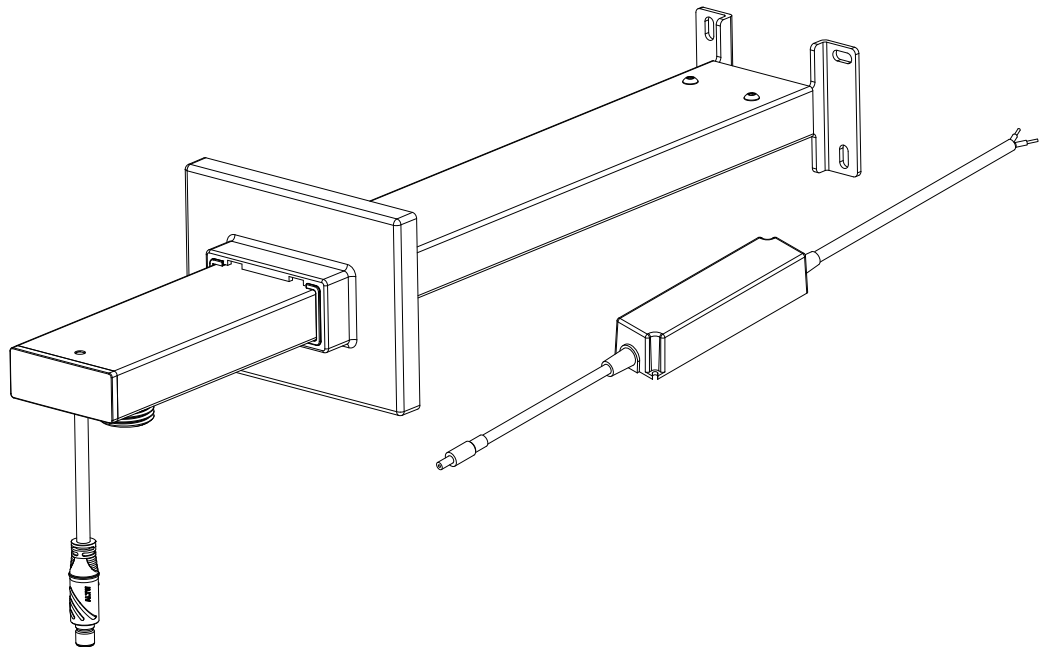

- x1 Wall Arm Assembly
- x1 Power Supply

3 Installation

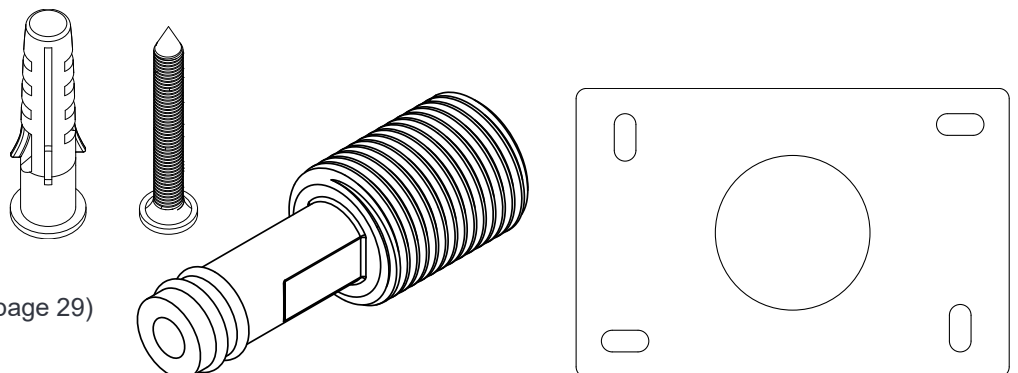

- x1 Water Path Connector
- x1 Hole Guide (cut out from page 29)
- x4 Wall Screws
- x4 Wall Plugs

Contents

BubbleSpa Ceiling Arm

Your BubbleSpa shower includes the following assemblies and parts:

1 Showerhead

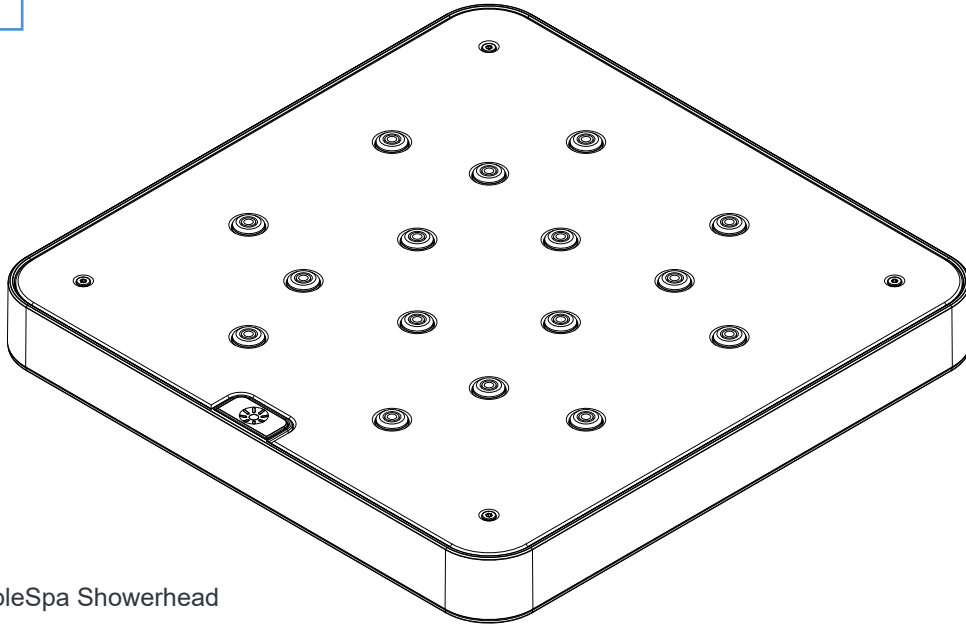

- x1 Kelda BubbleSpa Showerhead

2 Ceiling Arm

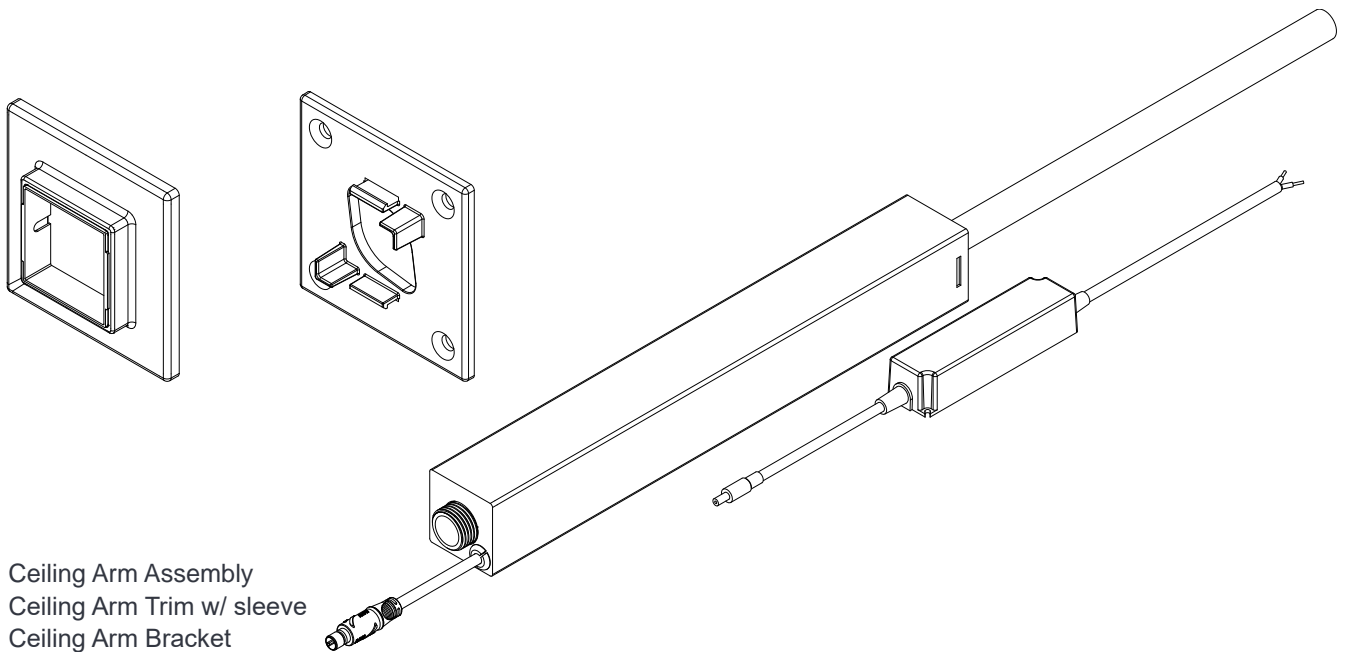

- x1 Ceiling Arm Assembly
- x1 Ceiling Arm Trim w/ sleeve
- x1 Ceiling Arm Bracket
- x1 Power Supply

3 Installation

- x1 1/2" BSP Nut
- x1 Olive
- x1 Mounting Plate
- x6 Screws
- x6 Wall plugs

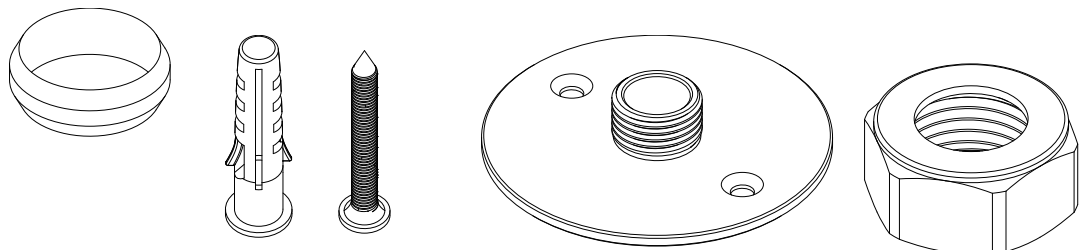

Wall Arm Installation

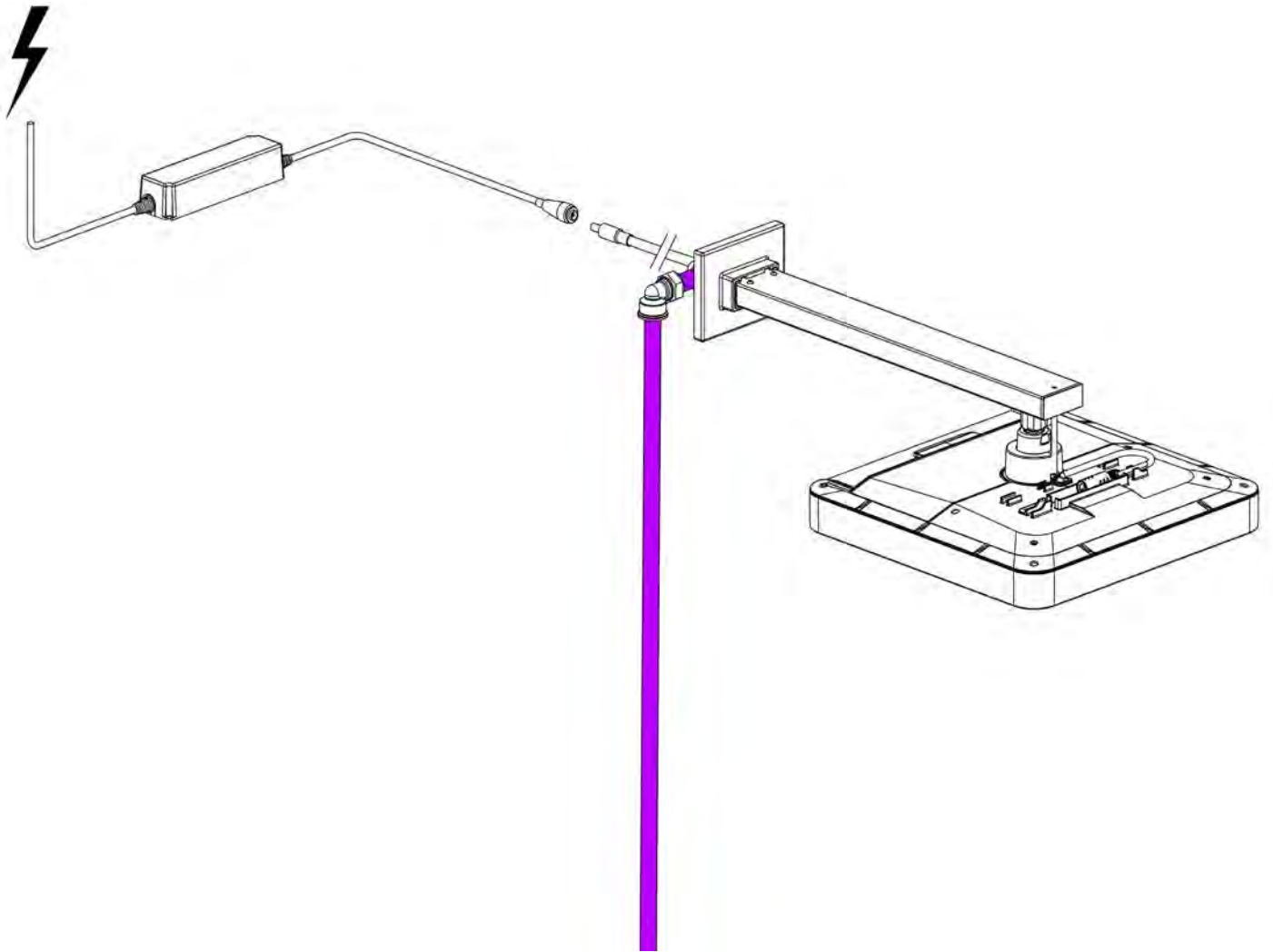

Wall Arm Installation



Warning: Read through to the end prior to commencing installation!

1

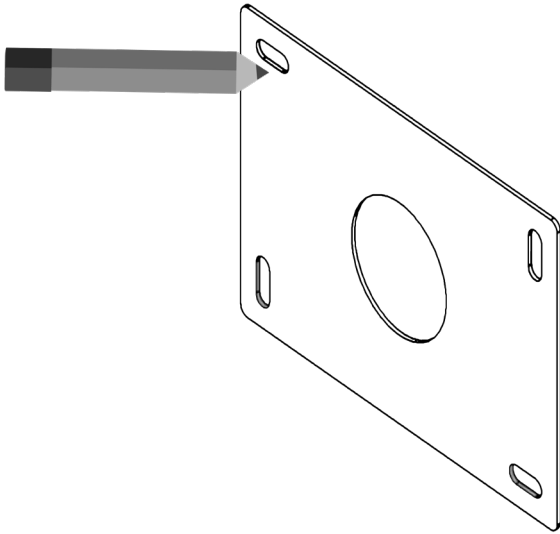

Using the guide provided on page 29, mark out and drill the holes for the Wall Arm Assembly around the pipe outlet. Ensure that the hole for the cable and outlet pipe is no bigger than 60mm diameter.

2

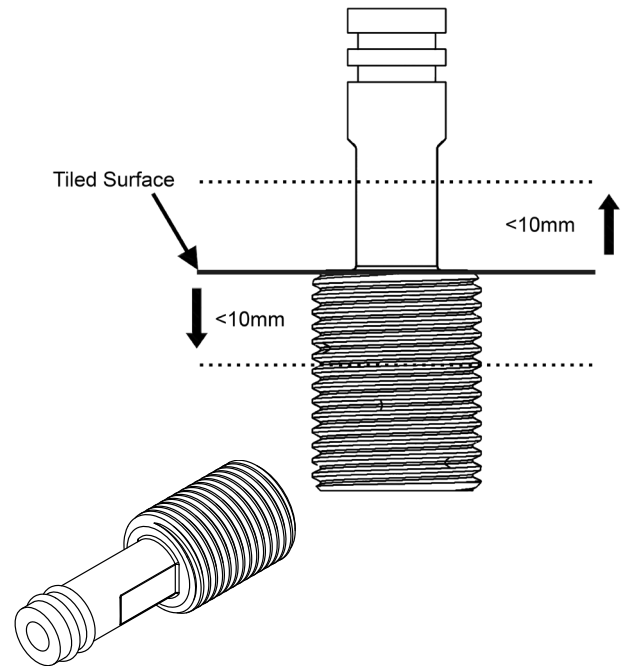

Screw the Water Path Connector to the outlet pipe. Ensure that the Water Path Connector is no more than 10mm proud of the wall tiles and is no more than 10mm inside the wall.

3

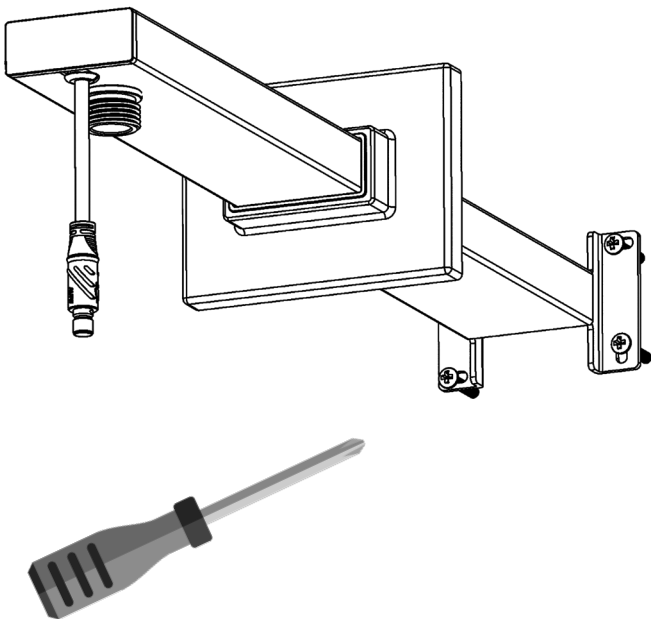

Feed the power cable of the Wall Arm Assembly into the wall. Then screw the Wall Arm Assembly to the wall using the Wall Screws and Wall Plugs provided.

4

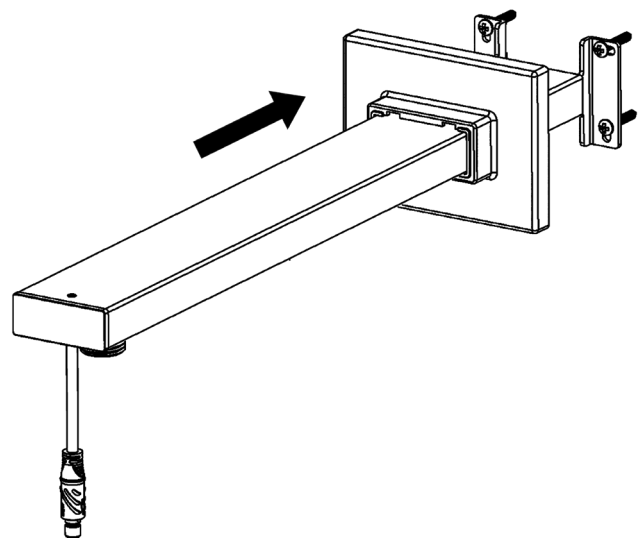

Slide the Wall Arm Trim and Trim Sleeve to the wall. Silicone may be added to the back of the Wall Arm Trim to fix it in position.

Wall Arm Installation

5

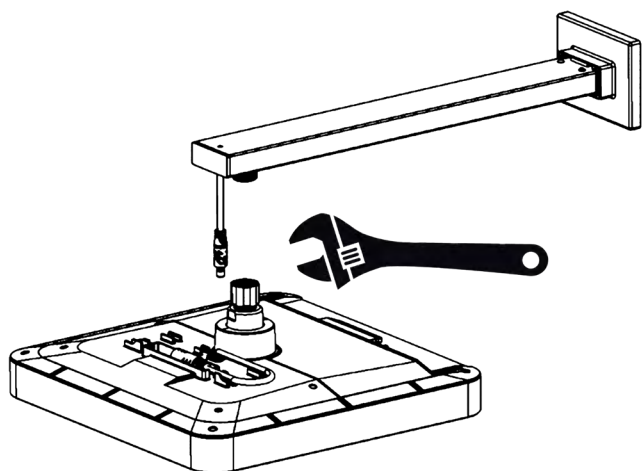

Screw the BubbleSpa showerhead onto the Wall Arm Assembly. Use a 23mm spanner on the top half of the Ball Joint and a 28mm Spanner on the bottom half of the Ball Joint.

6

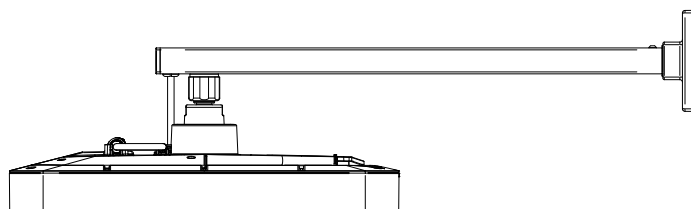

Ensure that the showerhead is horizontal. If the Wall Arm tilt slightly, tilt the showerhead to from the ball joint to compensate. The ball joint allows for a maximum tilt of 10°.

7

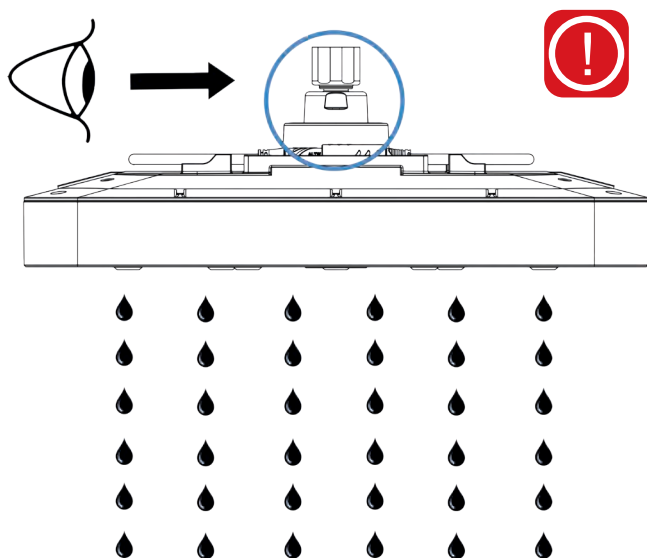

Run the showerhead without power to test the water supply. Whilst the shower is running check the Ball Joint and Flow Sensor Cover (circled) for any leaks. It is important that there is no water leaking as this can damage the fan and PCB. Make sure to also check the mixer operation, the temperature and the flow rate.

8

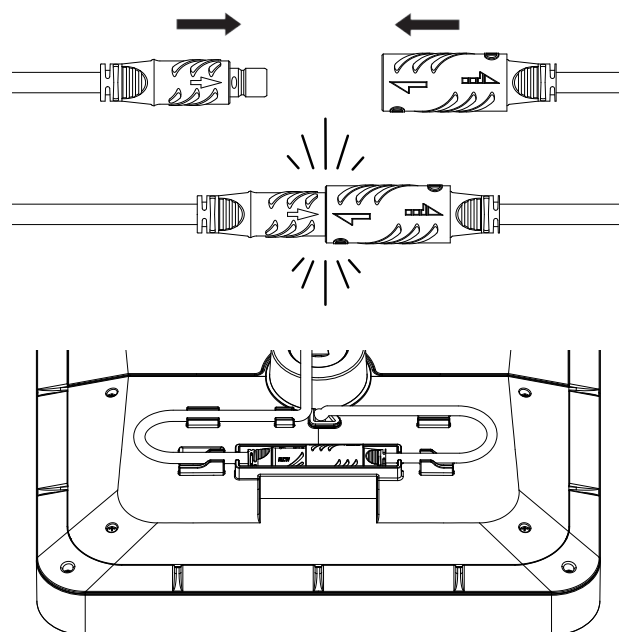

Switch off the water then attach the Power Cable by aligning the 2 arrows on the connectors and then pushing the connectors together until a click is heard. Then place the cables into the clips on the showerhead. Turn on the power supply to the showerhead.

Wall Arm Installation

9

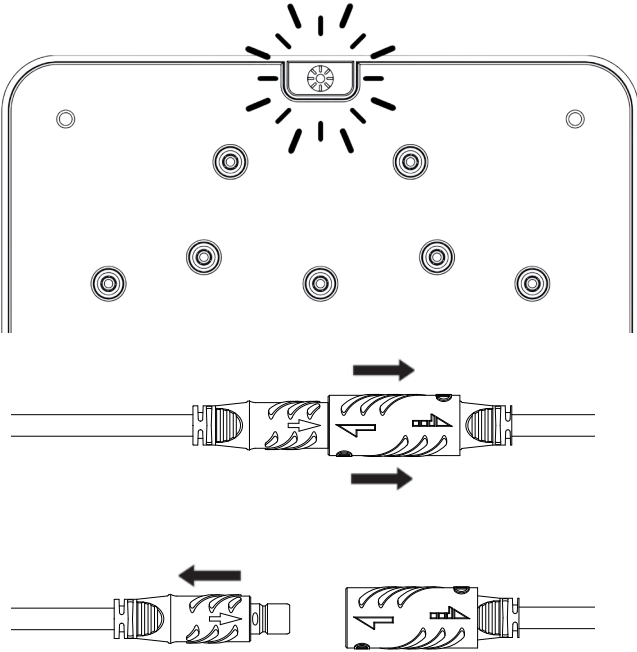

Once the power is turned on, the Button Light on the showerhead will light up. This is an indicator that power is being supplied to the showerhead. If you need to disconnect the power cable, first isolate the mains. Then pull back the outer layer of the larger connector then remove the small connector.

10

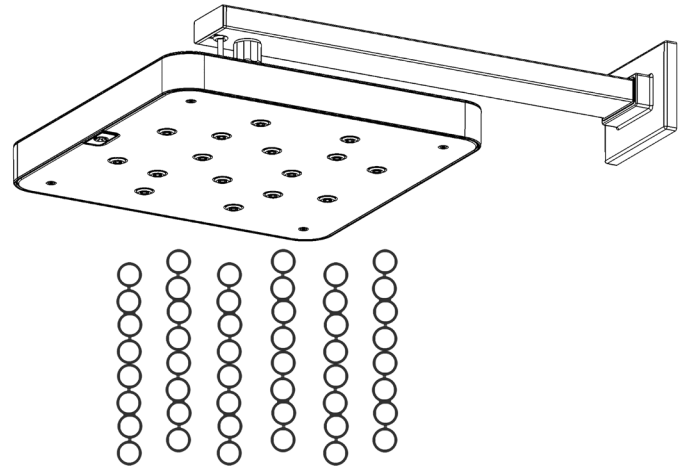

Run the showerhead with power to test the air and water supply, we recommend running this test at 38°C. Please note the bubbles don't form as consistently below 20°C. Once you are satisfied with the bubbles, remove the protective film from the faceplate and enjoy your BubbleSpa shower.



Warning!

- Always check for hidden pipes and cables before drilling
- Run water through hot and cold pipes to clear debris from pipework before connecting Kelda BubbleSpa Shower

Ceiling Arm Installation

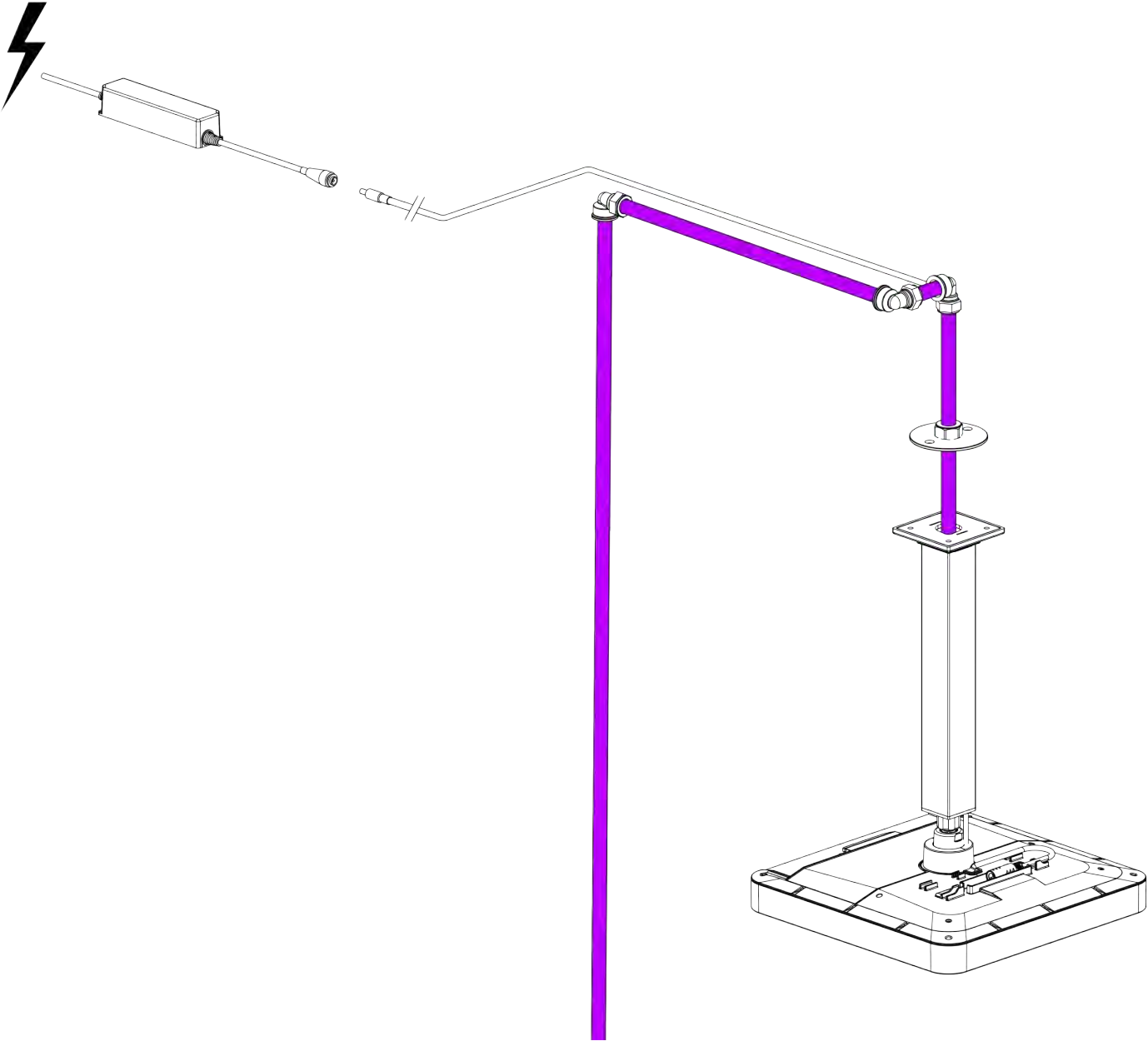

Ceiling Arm Installation



Warning: Read through to the end prior to commencing installation!

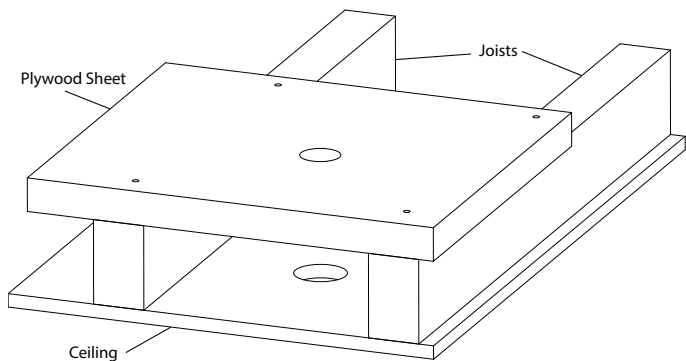

It is recommended to use a sheet of plywood supported by joists to fix the pipe mount permanently as shown above. Before installing, make sure the inner pipe of the Ceiling Arm Assembly is long enough to reach above the plywood sheer – cut the inner pipe if it is too long. Once the position of the shower has been determined, drill a hole that is bigger than 17mm but no larger than 60mm diameter in the ceiling.

1

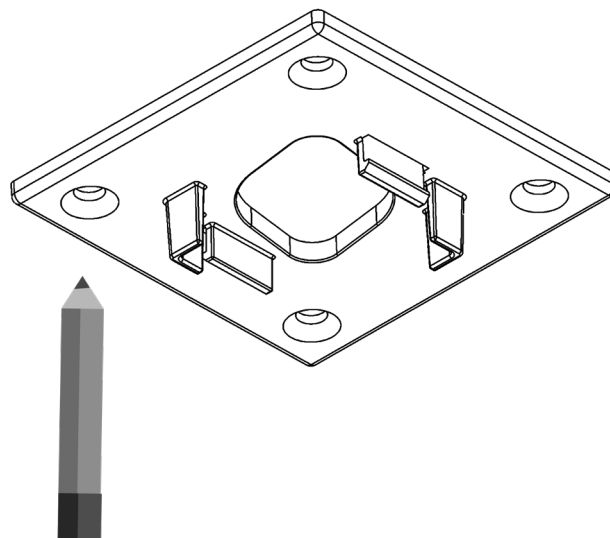

Using the Ceiling Arm Bracket as a guide, mark and drill the holes for the Wall Plugs on the ceiling of the shower cubicle.

2

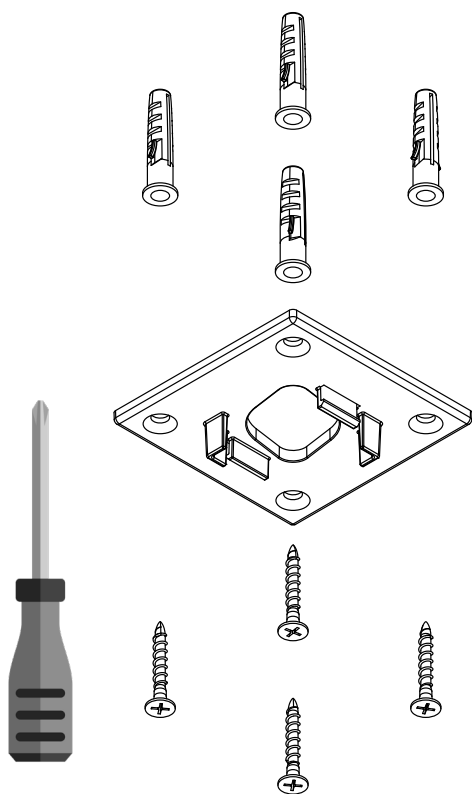

Insert the Wall Plugs provided into the ceiling and screw the Ceiling Arm Assembly using the screws provided.

3

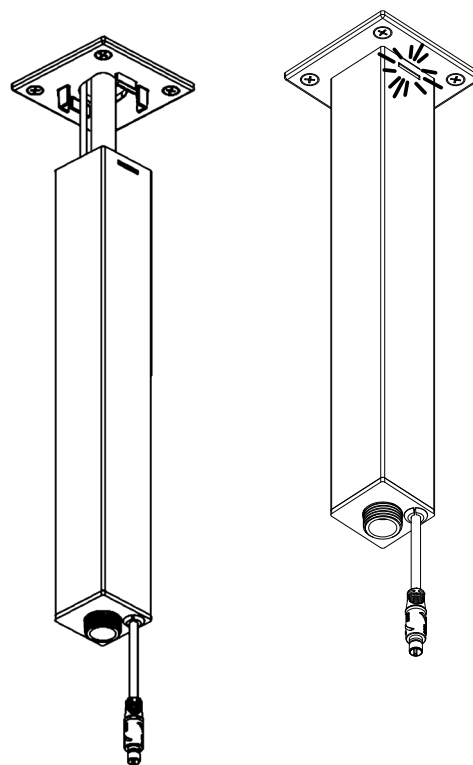

Feed the power cable of the Ceiling Arm Assembly into the void. Attach the Ceiling Arm Assembly to the Ceiling Arm Bracket. The Ceiling Arm Assembly will snap onto the bracket. The inner tube will go through the hole with sufficient length to attach the water supply. The inner tube may be cut to length if it too long.

Ceiling Arm Installation

5

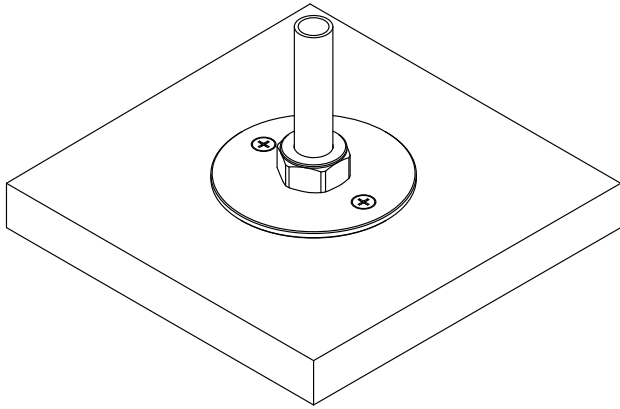

In the ceiling void, place the Mounting Plate over the inner tube. Attach the Mounting Plate to the plywood with the screws provided. Then place the olive and 1/2" BSP nut over the inner tube and tighten the nut.

6

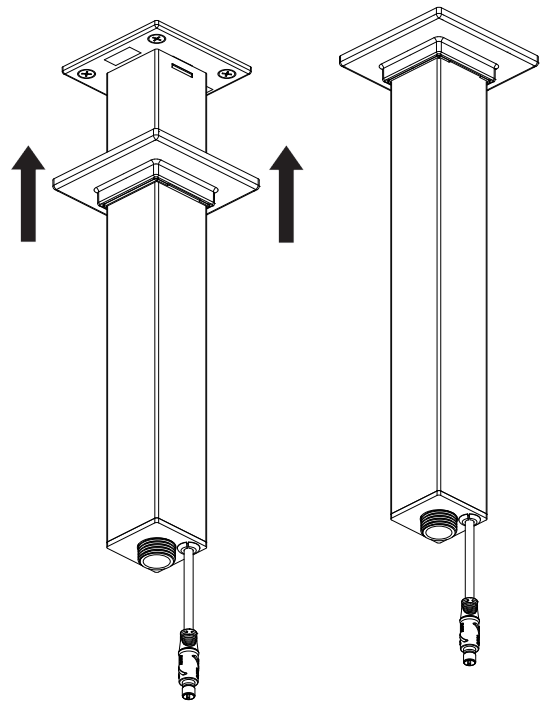

Peel back the double-sided tape on the Ceiling Arm Bracket and slide on the Ceiling Arm Trim. The Ceiling Arm Trim should stick to the tape. Silicone may be added on the back of the Ceiling Arm Trim to help it stick.

7

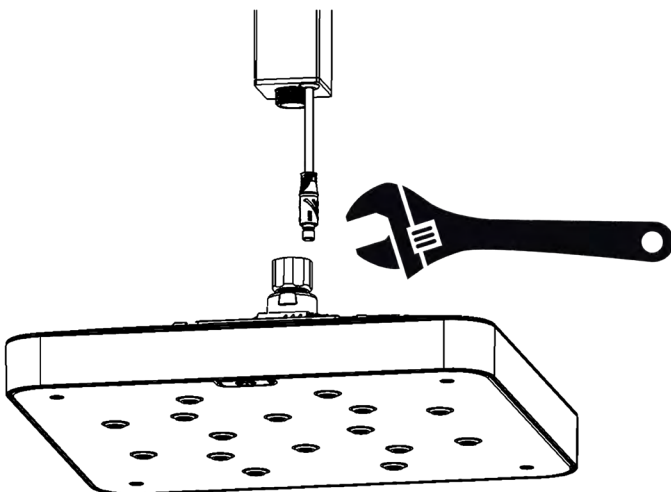

Screw the BubbleSpa showerhead onto the Ceiling Arm Assembly. Use a 23mm spanner on the top half of the Ball Joint and a 28mm Spanner on the bottom half of the Ball Joint.

8

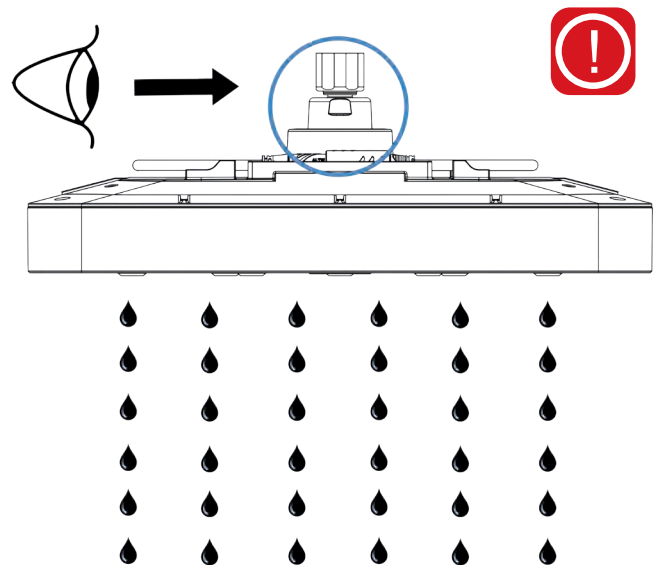

Run the showerhead without power to test the water supply. Whilst the shower is running check the Ball Joint and Flow Sensor Cover (circled) for any leaks. It is important that there is no water leaking as this can damage the fan and PCB. Make sure to also check the mixer operation, the temperature and the flow rate.

Ceiling Arm Installation

9

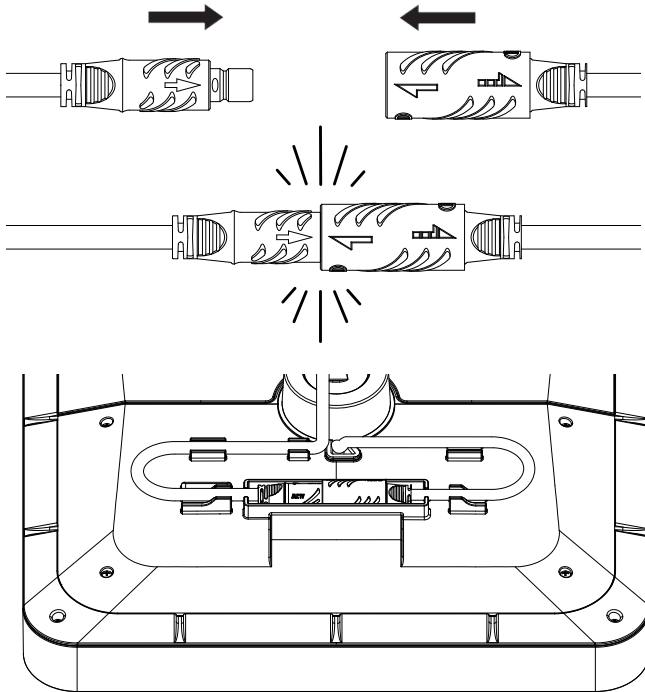

Switch off the water then attach the Power Cable by aligning the 2 arrows on the connectors and then pushing the connectors together until a click is heard. Then place the cables into the clips on the showerhead. Turn on the power supply to the showerhead.

10

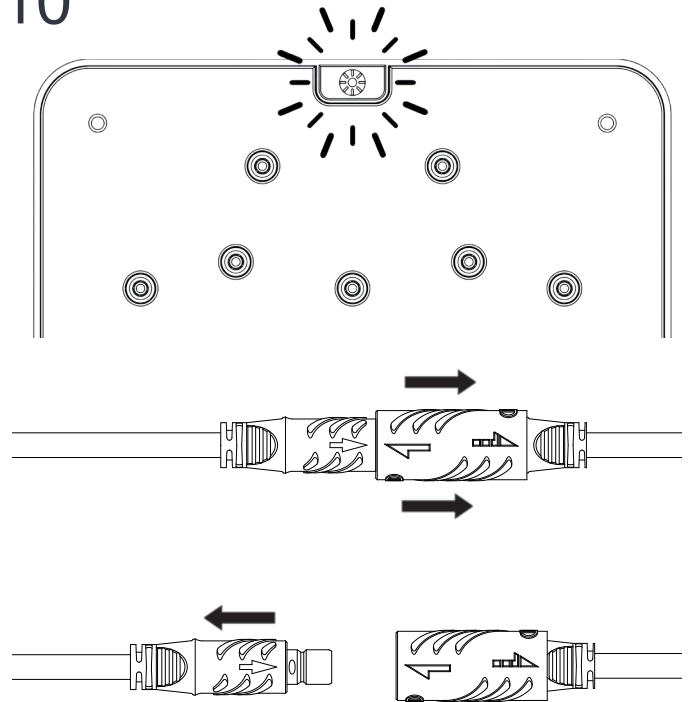

Once the power is turned on, the Button Light on the showerhead will light up. This is an indicator that power is being supplied to the showerhead. If you need to disconnect the power cable, first isolate the mains. Then pull back the outer layer of the larger connector then remove the small connector.

11

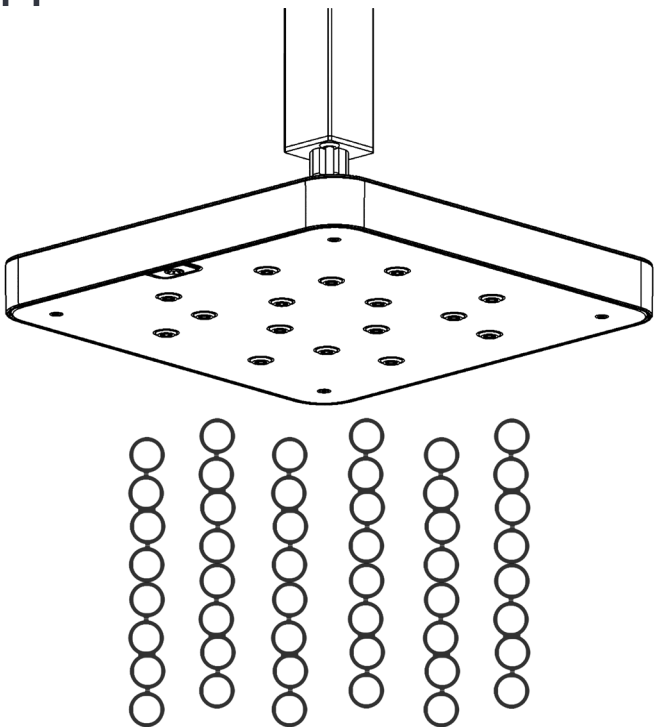

Run the showerhead with power to test the air and water supply, we recommend running this test at 38°C. Please note the bubbles don't form as consistently below 20°C. Once you are satisfied with the bubbles, remove the protective film from the faceplate and enjoy your BubbleSpa shower.

Warning!



- Always check for hidden pipes and cables before drilling
- Run water through hot and cold pipes to clear debris from pipework before connecting Kelda BubbleSpa Shower

Electrical Installation

This shower requires a 100-240 VAC, 47 ~ 63Hz single phase supply. A single 3 Amp switched fused spur should be used for each Panel. Up to 12 Kelda showers can run from a single 32A 30mA RCBO.

Before connecting to power supply, make sure that the mains terminal is able to sustain 240V and 3A. All electrical installation to be carried out by an approved electrician in accordance with Part "P" U.K. Building Regulations and to the latest IEEE standards, or the appropriate regulations in the country of installation.

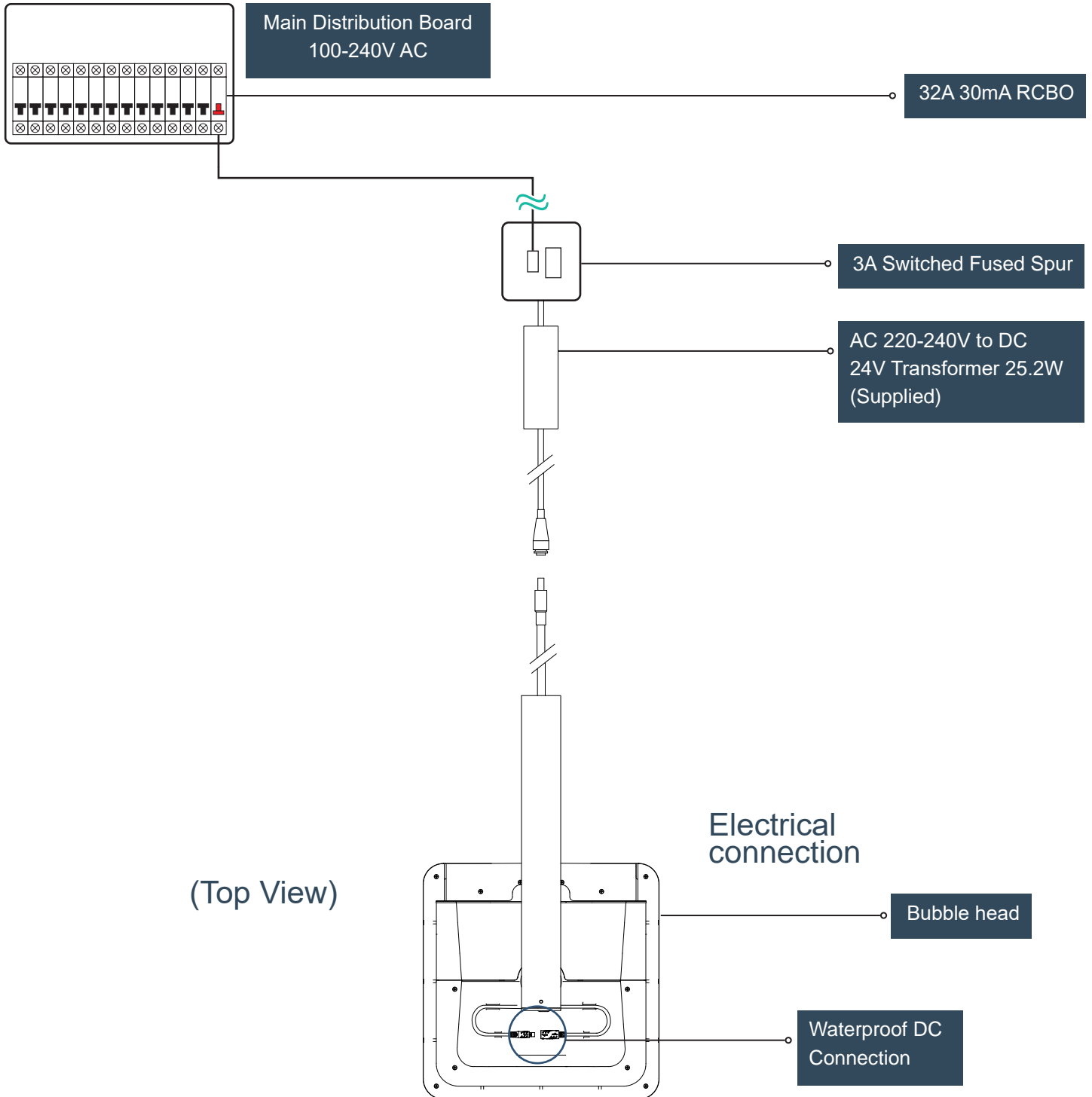

*The BubbleSpa showerhead does not require its own [electrical port] on the RCB. Since BubbleSpa can be run from a port being used eg. Kitchen port or lighting. See next page for full details.

Electrical Installation

Meanwell Customised 24V LPF Series Unit



IP67 - Fully Encapsulated
Class 2 Power Unit

| Output | |
|-------------------------|------------|
| DC Voltage | 24V |
| Constant Current Region | 13.2 ~ 24V |
| Rated Current | 1.05A |
| Rated Power | 25.2W |

| Input | |
|-----------------|--|
| Voltage Range | 90 ~ 305VAC |
| Frequency Range | 47 ~ 63Hz |
| AC Current | 0.4A / 115VAC 0.25A / 230VAC 0.2A / 277VAC |

Protection

| | |
|------------------|---|
| Over Current | 95-108% Constant current limiting, recovers automatically after fault condition is removed |
| Short Circuit | Hiccup mode, recovers automatically after fault condition is removed |
| Over Voltage | 28-35V Shut down and latch off o/p voltage, re-power on to recover |
| Over Temperature | Shut down o/p voltage, recovers automatically after temperature goes down |

Environment

| | |
|------------------------|---|
| Working Temp. | Tcase= -35~+70°C |
| Max. Case Temp. | Tcase= +70°C |
| Working Humidity | 20 ~ 95% RH non-condensing |
| Storage Temp. Humidity | -40 ~+80°C, 10 ~ 95% RH |
| Temp. Coefficient | +/-0.03%/°C (0 ~ 50°C) |
| Vibration | 10 ~ 500Hz, 5G 12min./1cycle, period for 72min. each along X, Y, Z axes |

Safety & EMC

| | |
|----------------------|--|
| Safety Standards | UL8750, CSA C22.2 No.250.0-08; ENEC BS EN/EN61347-2-13 independent, BS EN/EN62384, J61347-2-13, EAC TPTC 004, GB19510.14, IP67 approved; Design refer to UL60950-1 |
| Withstand Voltage | I/P-O/P:3.75KVAC |
| Isolation Resistance | I/P-O/P: 100M Ohms / 500VDC / 25°C / 70% RH |
| EMC Emmission | Compliance to BS EN/EN55015, BS EN/EN61000-3-2 Class C (@load≥50%) ; BS EN/EN61000-3-3, GB17743 and GB17625.1, EAC TP TC 020 |
| EMC Immunity | Compliance to BS EN/EN61000-4-2,3,4,5,6,8,11; BS EN/EN61547, light industry level (surge immunity Line-Line 2KV), EAC TP TC 020 |



User Guide (BubbleSpa Showerhead)



Bubble effect light settings

Your Kelda Bubble Spa showerhead comes with a selection of light modes to give you a satisfying Bubble experience no matter what your mood is or the time of day. The light modes can be activated both when the shower is on (Wet Working mode) or when the shower is off (Dry Demo mode).

Wet Working mode

Wet working mode is automatically activated when water flows through the BubbleSpa head. The default light setting is “1 Low” (see table below). The BubbleSpa shower will return to this setting in the event of the power supply being disconnected.

To change your Bubble light setting simply press the illuminated button in the faceplate.

| Brightness | Bubble Mode | | |
|--|--------------------------------------|---|---|
| Off | Bubbles not visible to the naked eye | | |
|  Low | 1 | 2 | 3 |
|  Medium | 1 | 2 | 3 |
|  High | 1 | 2 | 3 |

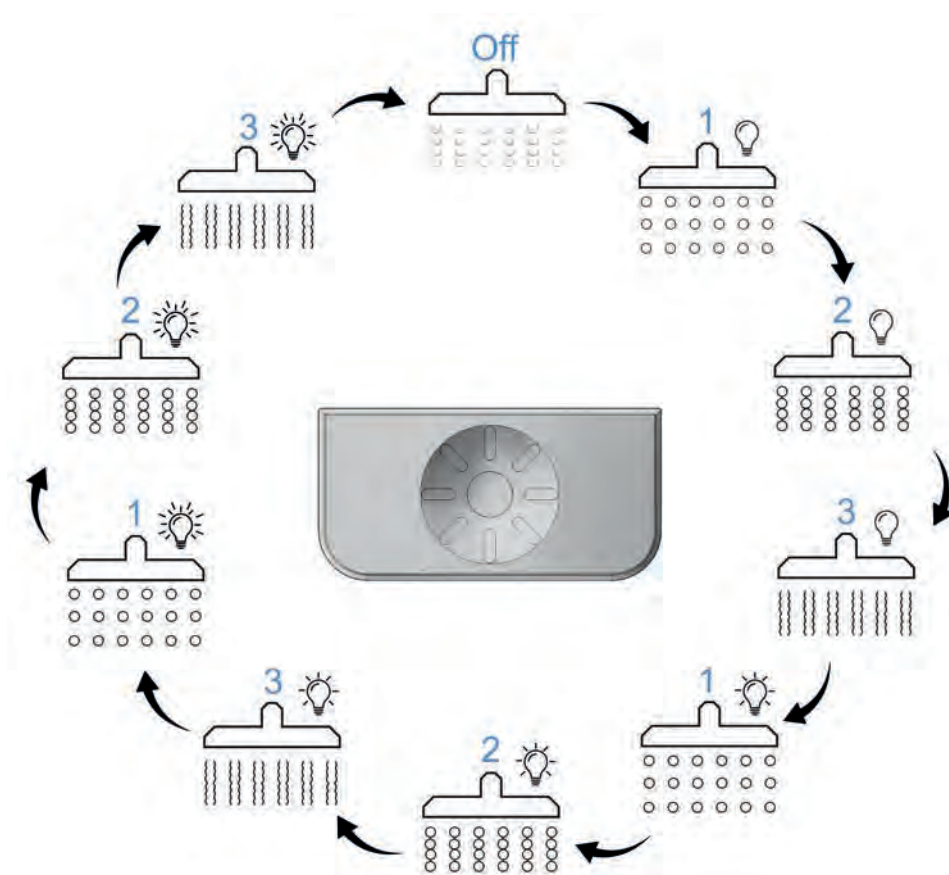

**Visual representation of how bubbles LOOK at different settings. Pressing the button does not change the frequency of bubbles or flow rate of the Bubble Spa shower.*

- The image above shows the cycle of Bubble Modes
- Pressing and holding the button (for 1-2seconds) will turn the light off regardless of which Bubble Mode is currently selected
- When the water is turned off the Bubble Mode is stored ready for your next shower
- “Off” is also saved as a setting – if you find the water on but the main LED array isn’t illuminated, it’s likely that the Bubble Mode was set to off by the last user. Simply press the button to cycle to the next Bubble Mode

User Guide (BubbleSpa Showerhead)

Dry 'Demo' mode

| Brightness |
|------------|
| Off |
| Low |
| Medium |
| High |

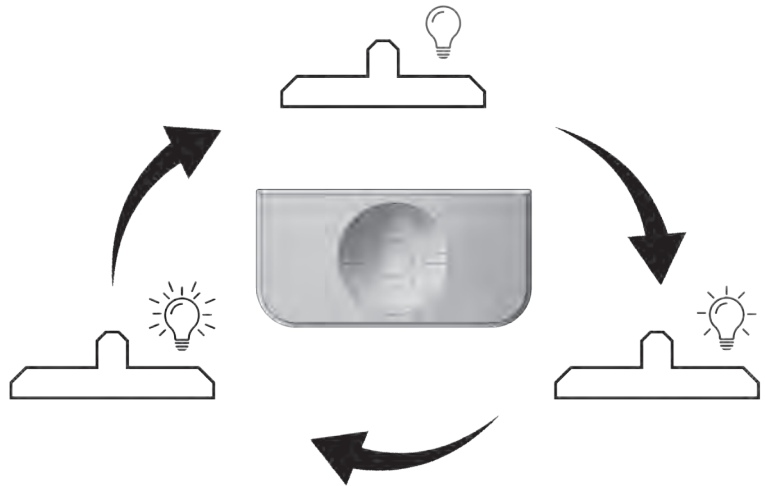

- To activate Demo mode press the button when the shower is off. To deactivate, press and hold for 2 seconds.
- Press the button to change the brightness of the light during dry mode
- The image above shows the Dry Mode cycle when the button is pressed
- Wet Working mode is automatically activated when water is turned on the Bubble Spa shower
- A longer press (1-2seconds) will turn the light off regardless of what mode is currently selected

Diagnostic Function

With the light and water off, press and hold the button for at least 5 seconds to engage the diagnostic tool. During this function the main light array and the fan will turn on. To switch off the fan and light, simply let go of the button. Use this tool to check the function of the fan and LED.

After Use

After using the showerhead, users are advised to tilt the showerhead. This drains the water inside of the water chamber.

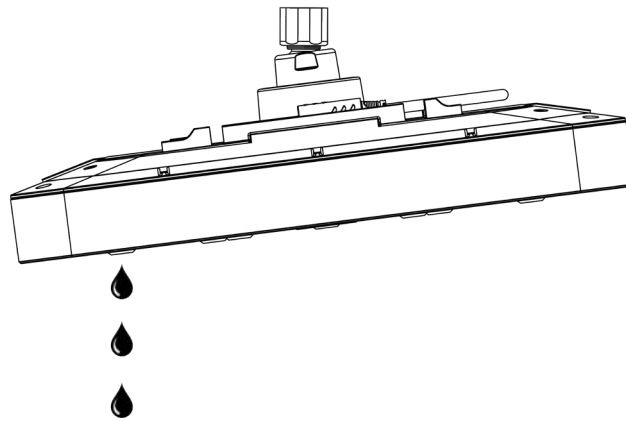

Flashing Lights!

This product uses flashing lights at frequencies of 72Hz, 200Hz and 10,000Hz. The effect of the lighting modes will vary depending on ambient lighting and the environment in which it is installed. Anyone diagnosed with a condition which could be triggered by flashing lights should seek further medical advice.



| Bubble Mode | Frequency |
|-------------|-----------|
| 1 | 72Hz |
| 2 | 200Hz |
| 3 | 10,000Hz |

Maintenance

Kelda showers are designed for easy maintenance and should give a safe and consistent performance, provided that:

1. Kelda showers are installed, commissioned, operated and maintained in accordance with this installation guide.
2. Periodic attention is given as necessary to maintain the product in good functional order.

Maintenance must be carried out in accordance with these instructions, and must be conducted by designated, qualified and competent personnel. Kelda showers are built with the highest quality components which are designed for a long life, but due care must be taken during maintenance to avoid damage.

External Surfaces

External surfaces of the showerhead may be wiped clean with a soft cloth and if necessary, a mild cleaning or descaling solution can be used. Always remove cleaning agent residue as this can discolour the surface. Care must be taken not to allow bleach, chlorine or other strong cleaning agents onto or inside the product.

Cleaning Dust Filters

The Dust Cap can be removed from the BubbleSpa showerhead in order to clean the Dust Filters. The Dust Filters can be removed and cleaned. Ensure that the Dust Filters are dry upon replacement.

1

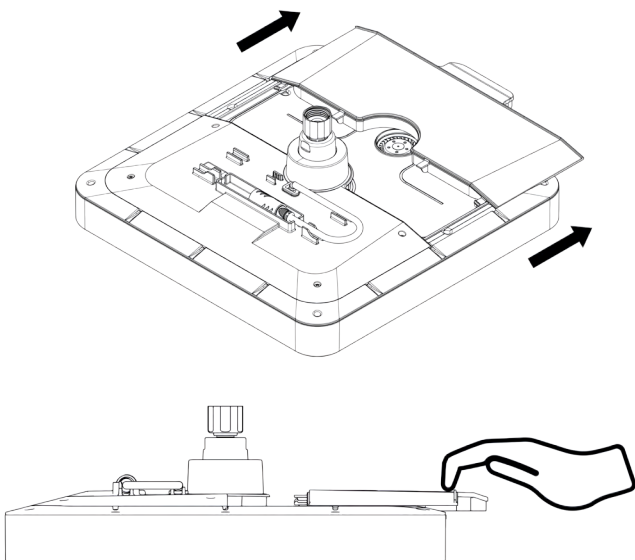

2

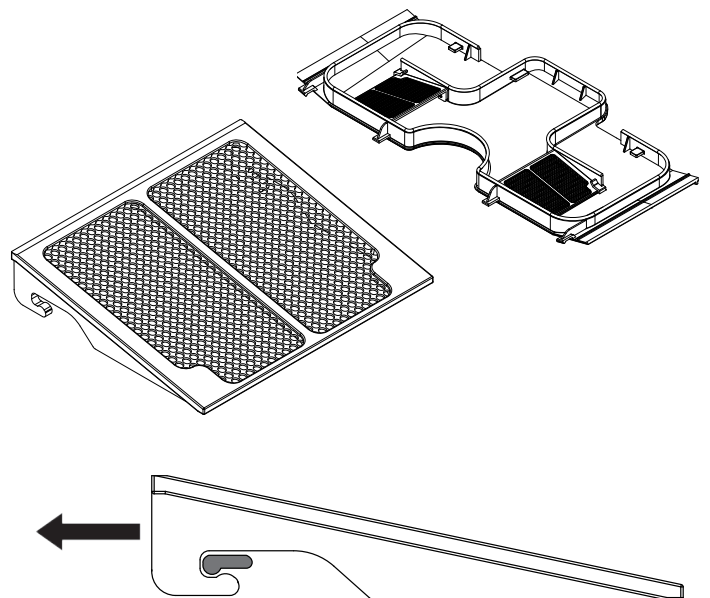

Switch off the water and power supply and disconnect the power cable. Then dismantle the showerhead using a spanner and place it onto a soft cloth. Then slide the Dust Cap off the showerhead as shown with both hands. When dismantling the showerhead be careful not to get any water onto the fan or PCB.

Remove the Dust Filters from the Dust Cap as shown and clean the Dust Filters.

Maintenance

3

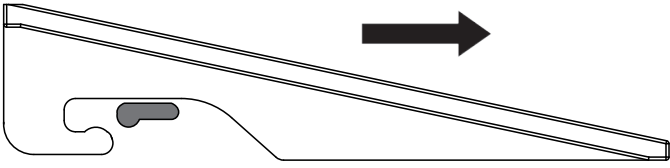

Dry the Dust Filters and place them back into the Dust Cap. Make sure the Dust Filters are secured tightly in the Dust Cap.

4

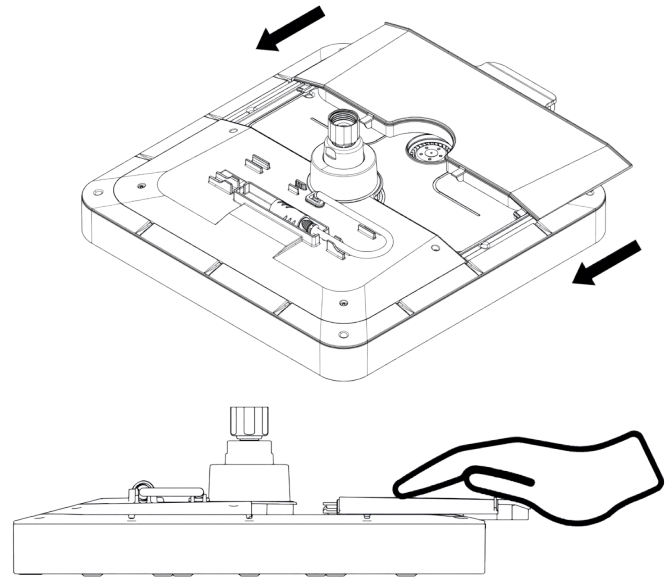

Slide the Dust Cap onto the showerhead. Make sure the Dust Cap is secured tightly and then mount the showerhead onto the arm using a spanner. Reconnect the power cable and switch on the power and water supply.

Things to avoid

To keep the BubbleSpa shower functioning well, please avoid the following:

- Blocking the nozzles while the BubbleSpa is running
- Hanging items on the BubbleSpa showerhead or arm assemblies
- Using the BubbleSpa shower without a PCB Cover or Dust Cover with Dust Filters

Be careful not allow water into the fan when:

- Fitting/ Removing the BubbleSpa showerhead
- Spraying any additional water source up at BubbleSpa shower
- Descaling the showerhead (page 24)



Warning!

DO NOT SUBMERGE the BubbleSpa showerhead!



Maintenance

Changing Flow Regulator (Flow Restrictor)

The BubbleSpa shower comes with a flow regulator installed. This can be changed by unscrewing the BubbleSpa showerhead from the Arm Assembly and removing the flow regulator from inside the Ball Joint. The flow regulator is underneath the filter. Place the new flow regulator, ensure that the orientation of the flow regulator is correct. Then place the filter back and screw the BubbleSpa shower back onto the Arm Assembly. The BubbleSpa shower operates at a range of 8 – 12L/min. Using the showerhead without a Kelda supplied flow regulator will void the warranty and negatively affect the performance of the product.

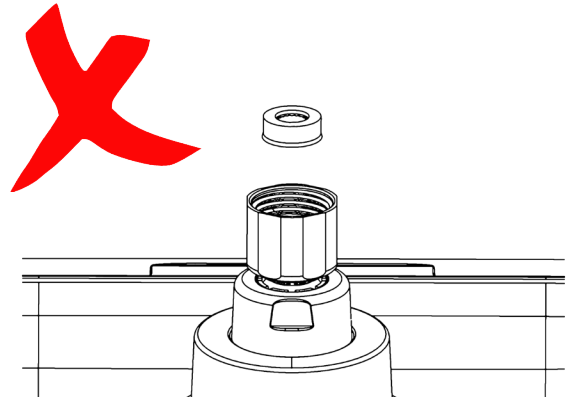
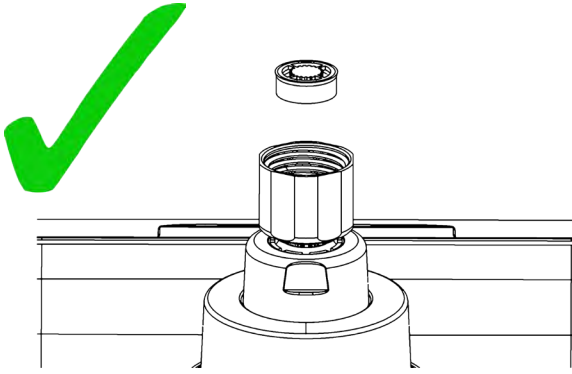

Descaling the BubbleSpa showerhead

1

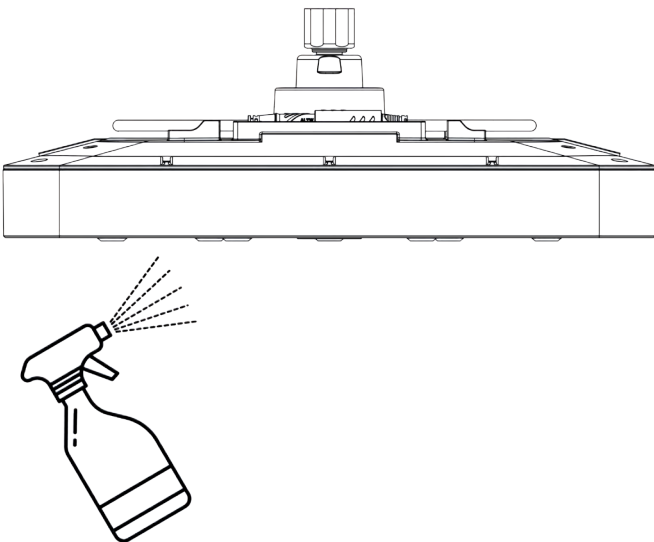

Spray cleaning solution onto the faceplate.

2

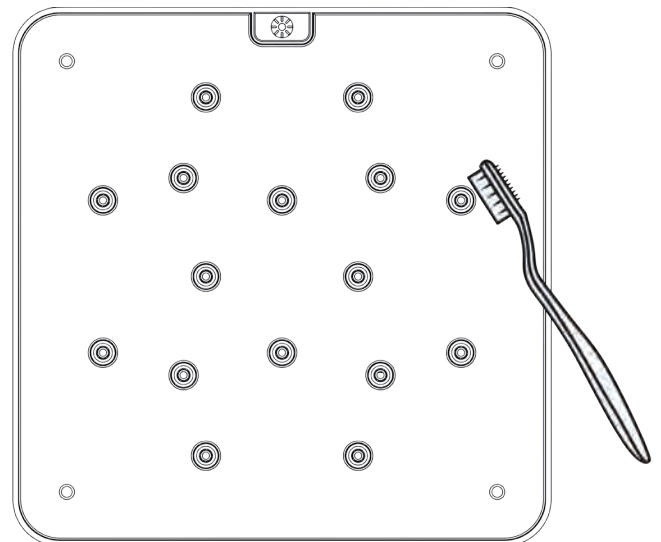

Clean the nozzles using a soft brush.

Maintenance

3

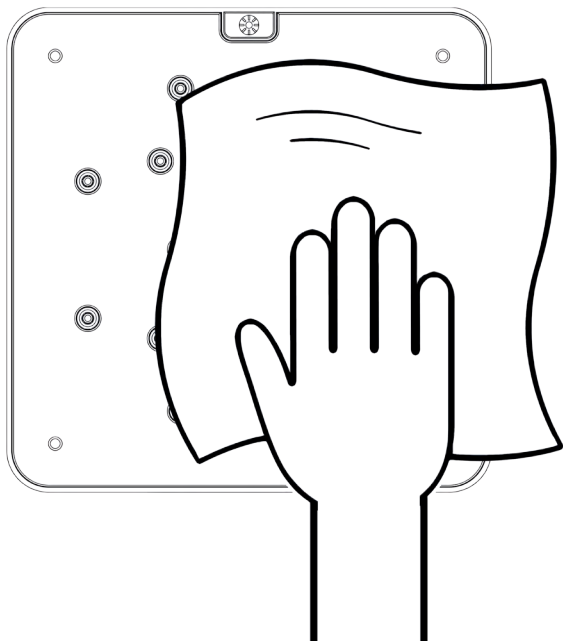

Wipe the faceplate using a damp cloth to remove the loosened debris.

4

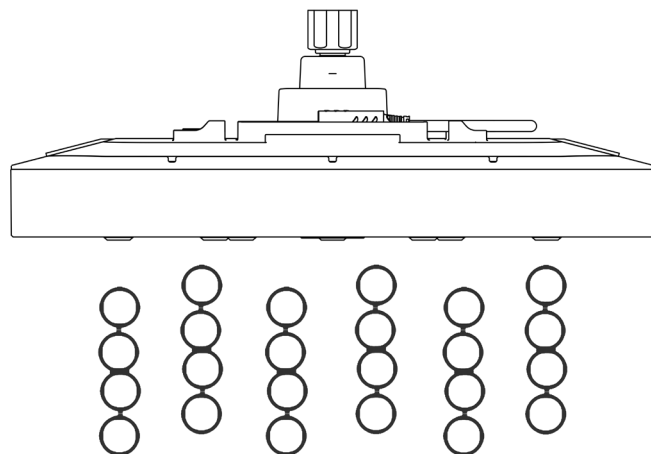

Run the shower for 1-2 minutes to flush out any cleaning solution and debris.

The frequency of the maintenance required is dependent on the usage and the hardness of the water in your area.

Troubleshooting

Before troubleshooting, ensure that the correct installation, usage and maintenance procedures have been followed. Improper installation and improper use of the product can cause a lot of issues. The guide below is designed to help identify and solve minor issues which may occur. If the issue is still not resolved, please contact Kelda Customer Service:

info@keldashowers.com
+44 (0)2381 290640

DO NOT disassemble the BubbleSpa showerhead beyond the instructions contained in this manual. Disassembling the BubbleSpa showerhead will invalidate the warranty.

BubbleSpa Showerhead

| Symptom | Likely Cause | Action/ Remedy |
|---|---|--|
| Poor/ No water flow: | Hot or cold water supply isolation valve closed | Check and open valve |
| | Blocked filter | Unscrew the BubbleSpa showerhead from the arm, remove and clean filter, replace filter. Clean the mixer valve filter |
| | Mixer valve not functioning. | Check mixer valve |
| Water flows from showerhead but no air: | No power to the fan | Check power light indicator, if off contact a qualified electrician If power light indicator is on, conduct hard reset by switching off electrical supply and waiting 10 seconds before turning on. |
| | Fan Damaged | Use Diagnostic Function to see if the fan is working. If not, contact Kelda |
| | Debris in fan | Clean the Dust Filters |
| One/ a few nozzles aren't making bubbles: | No laminar flow through nozzle | Gently brush a finger against the nozzle whilst the shower is running |
| | Faulty nozzle is blocked | Descale the showerhead to remove debris (see page 24). Check the filter is installed correctly (both the showerhead and valve) and clean |
| | Insufficient water supply | Increase the water flow to the shower. |
| Multiple/ all nozzles aren't making bubbles | Insufficient water supply | The fan wont turn on below 6L/min therefore no bubbles will be produced. Increase the water flow to the shower. |
| | Limescale/ Debris build up in the nozzles | Descale the BubbleSpa showerhead (see page 24). It is recommended not to leave the BubbleSpa showerhead unused for more than 2 weeks. |
| Water flow too strong: | Flow restrictor not installed. | Check if the flow restrictor is properly installed (see page 24) |

Customer care

Guarantee

Kelda Showers Ltd. guarantees this product against any defect in materials or workmanship for the period of two years from the date of purchase. To be covered by this guarantee, installation and maintenance should be carried out as described in this manual.

Not covered by this guarantee

Damage or defects arising from incorrect installation, improper use or failure to maintain in accordance with the instructions in this product manual, including the build-up of lime-scale. Defects or damage if the product is taken apart, repaired or modified by a person not authorised by Kelda Showers Ltd. or by their approved agents.

After-sales service

Our fully trained staff are ready to provide assistance, should you experience any difficulty operating your Kelda Showers Ltd. equipment.

Spare parts

All spares are guaranteed for 12 months from date of purchase. Spares that have been supplied directly from us can be returned within one month from date of purchase,

Patents:

Patents
granted and
pending:
1692638P/US

providing that they are in good order and the packaging is unopened. Note: returned spares will be subject to a 15% restocking charge and authorisation must be obtained from Kelda Technology before return.

For the full list of spare parts, please refer to:
www.keldashowers.com/

Customer care policy

If within a short space of time of installation the product does not function correctly, first check with the operation and maintenance advice provided in this installation guide to see if the difficulty can be overcome. Failing this, contact your installer to make sure that the product has been installed and commissioned in full accord with our detailed installation instructions. If this does not resolve the difficulty, please contact Kelda Technology, who will give you every assistance.

Declaration of conformity

Kelda Showers limited declares that the Deluxe Panel Shower complies with the essential requirements and other relevant provisions of the Low Voltage Directive (2014/35/EU) and the EMC Directive (2014/30/EU).





UK HEAD OFFICE

Unit 11, Brickfield Trading Estate, Chandler's Ford, Eastleigh,
SO53 4DR, UK

Tel: +44 (0)2381 290640

Web: www.keldatechnology.com



DISPOSAL

Do not dispose of with household waste. Please recycle where facilities exist.
Check with your local authority for recycling advice.

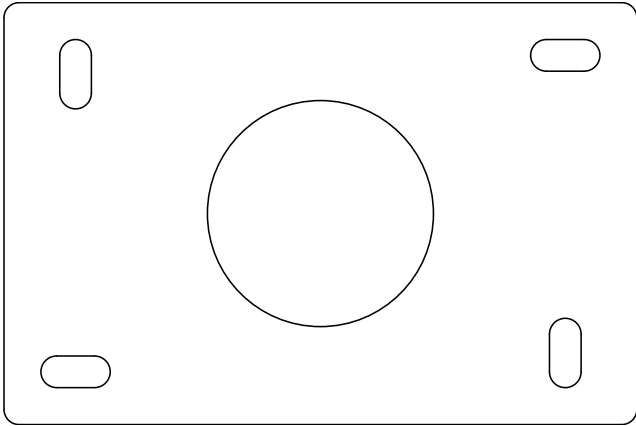

Cut out for installing the Wall Arm