

Rear Access Void Shower

Installation Manual and User Guide

Flex Head – Rear Void TMV2 Thermostatic	91017100
Flex Head – Rear Void TMV2 Thermostatic	91020100
Flex Head – Rear Void TMV2 Thermostatic	91021100

This shower must be used with compatible TMV2 shower mixer/valve or timed flow control valve

Important:

This product manual is the property of the customer and must be retained for maintenance and operational purposes.
SKU 91017100 shown on front cover.



Table of Contents

- 3 - Important Safety Information**
- 4 - Description**
- 5 - System Diagram**
- 6 - Specifications**
- 7 - Siting the Shower**
- 8 - Installation**
 - 8 - 1. Control Hub**
 - 9 - 2. Shower Head (Flex)**
 - 10 - 3. Hose Installation**
- 11 - Electrical Installation**
- 12 - Factory Settings**
- 14 - Troubleshooting**
- 14 - Operation**
- 15 - Maintenance/Cleaning**
- 17 - Spare Parts**
- 18 - Customer Care**
- 19 - Installation Templates**

SYSTEM DESCRIPTION

Flex Shower Head – 12 Nozzle – 91017100

Directional 12 nozzle shower head mounted onto service void wall with Chrome finish (Other finishes available on request). Rear service void mounted Control Hub with optional air recirculation.

FLOW VOLUME REGULATION

Flow volume (l/m) is controlled via a flow regulator.

The last digit of the product code will designate the flow regulator pre-fitted, for example:

91017104 : Flex Head – Rear Void Shower – 4 l/m

91017105 : Flex Head – Rear Void Shower – 5 l/m

91017106 : Flex Head – Rear Void Shower – 6 l/m

Important Safety Information

This product requires hot and cold water supply plus an electrical connection (see "Electrical Installation" on page 11 for details). This product is not an electric shower.

Products manufactured by Kelda Showers are safe and without risk provided they are installed, used and maintained in good working order in accordance with instructions and recommendations.

IMPORTANT! DO NOT operate the unit if the shower head becomes damaged.

IMPORTANT! DO NOT restrict flow out of shower by placing an obstruction in front of the shower head nozzles.

GENERAL

1. Read all of these instructions and retain them for later use.
2. DO NOT take risks with plumbing or electrical equipment
3. Isolate electrical and water supplies before proceeding with the installation.
4. The shower head must be cleaned regularly with descalant to remove scale and debris. The Air hoses must be cleaned periodically to maintain performance and hygiene. PLEASE SEE MAINTENANCE SECTION.
5. This product is not suitable for mounting into steam rooms or steam cubicles.
6. The shower should not be installed in an outdoor environment, including sheltered areas.

PLUMBING

1. The plumbing installation must comply with water regulations, building regulations or any particular regulations as specified by local water company or water undertakers and should be in accordance with BS EN 806 (Specifications for installations inside buildings conveying water for human consumption. Operation and maintenance).
2. **IMPORTANT! The hot and cold water supply pipes must be flushed to clear debris from before connecting to water inlets on shower.**
3. DO NOT solder pipes or fittings within 300mm of the supplied hoses, as heat can transfer along the pipework and damage components.
4. DO NOT use excessive force when making

connections to the flexible hose, solenoid or mixer.

5. All plumbing connections must be completed before making the electrical connections.
6. Kelda products are designed to operate between 1 bar (0.1 MPa) and 5 bar (0.5 MPa). If you wish to operate outside of this please discuss with a Kelda Engineer.

ELECTRICAL

1. The installation must comply with BS 7671 'Requirements for electrical installations' (IET wiring regulations), building regulations or any particular regulations as specified by the local electrical supply company.
2. In accordance with 'The Plugs and Sockets etc. (Safety) Regulations 1994', this appliance is intended to be permanently connected to the fixed wiring of the electrical mains system.
3. Make sure all electrical connections are tight to prevent overheating.
4. A 32A 30 mA Residual Current Circuit Breaker Operator (RCBO) with over current protection MUST be installed in all UK electric and pumped shower circuits. This may be part of the consumer unit or a separate unit.
5. Each shower must be connected to a 3A switched fused spur which is easily accessible. Switch off at fused spur for maintenance or if not in use for extended periods. This is a safety procedure recommended with all electrical appliances.
6. Make sure all electrical connections are tight to prevent overheating.
7. As with all electrical appliances it is recommended to have the shower and installation checked at least every two years by a competent electrician to ensure there is no deterioration due to age and usage.

Description

Control Hub

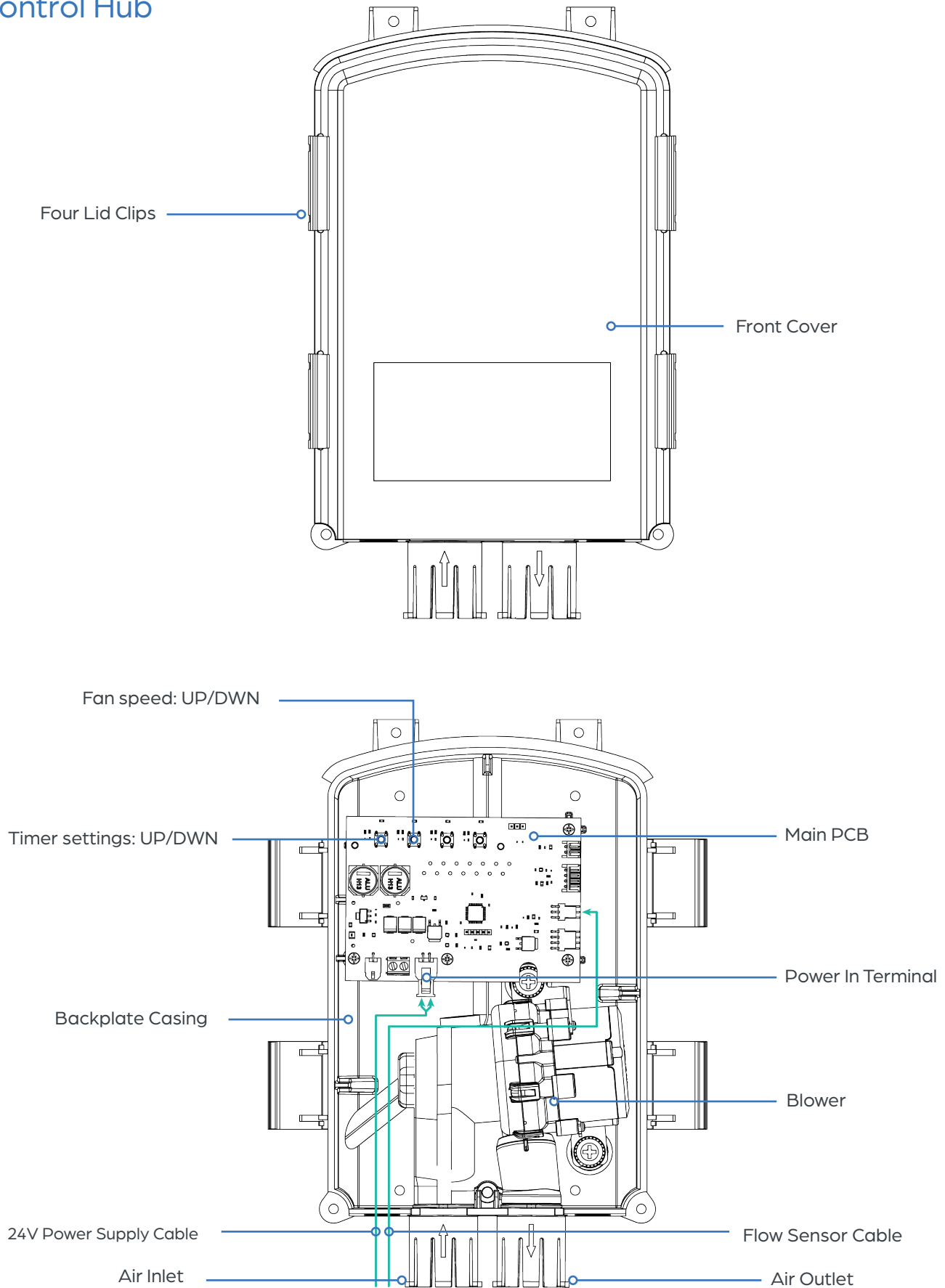

System Diagram (Flex Head – 91017100)

Flex Head – 91017100

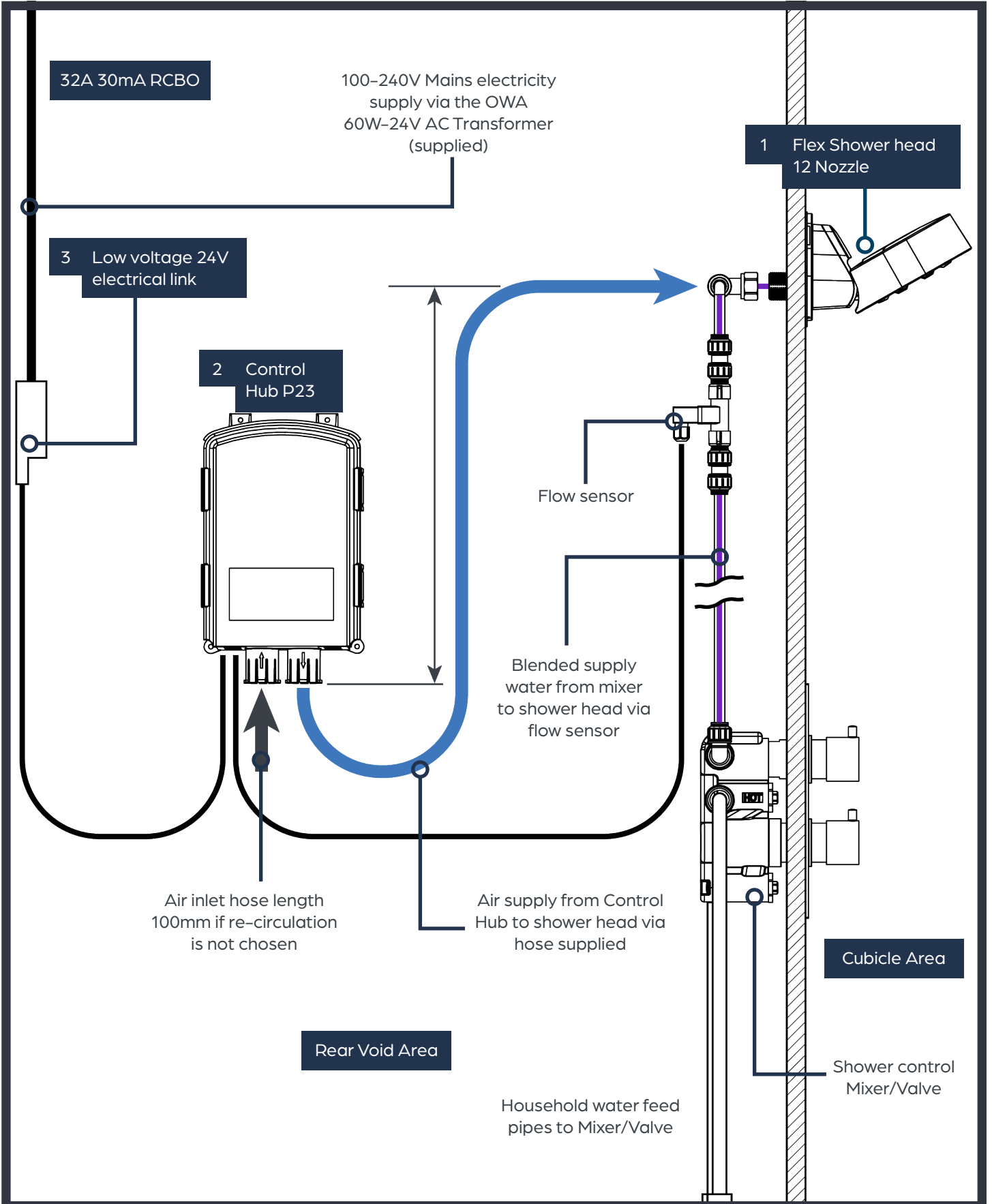

Specifications

Flex Head 91017100

You should have the following assemblies within your Flex head order:

1 Flex Shower Head

- x1 Bright chrome Directional shower head
- Flow sensor assembly
- x1 Fixing Kit:
 - x2 Fixing back nuts
 - x4 Screws
 - x4 Wall plugs
 - x1 Pipe spacer

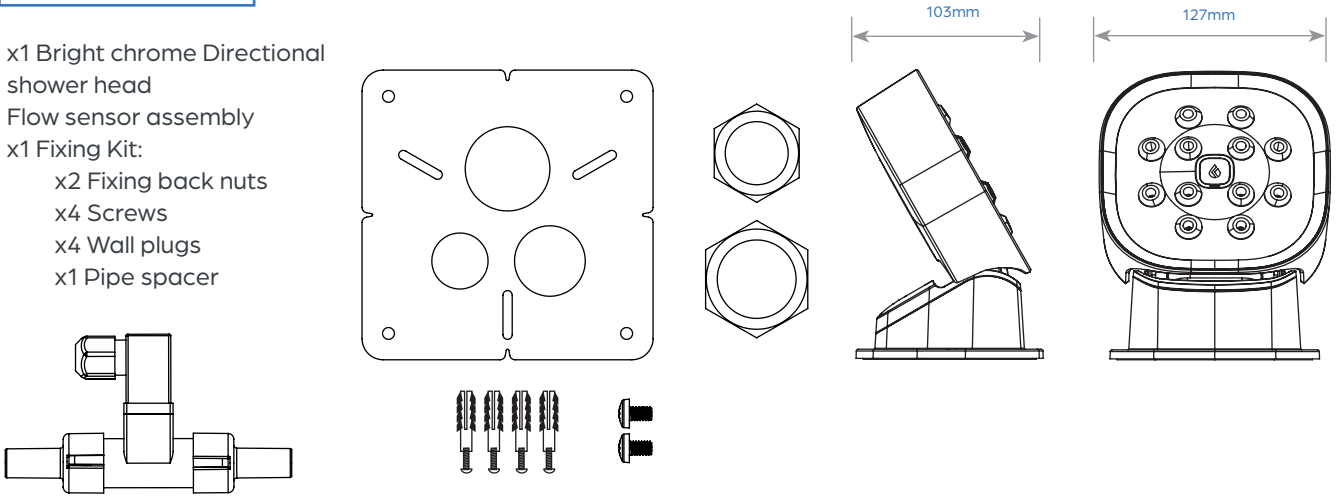

2 Hoses

- x1 Air supply hose
- x1 Air inlet hose
- x4 Jubilee Clips
- x1 90 degree elbow 19mm
- x1 3/4 Inch Air nut

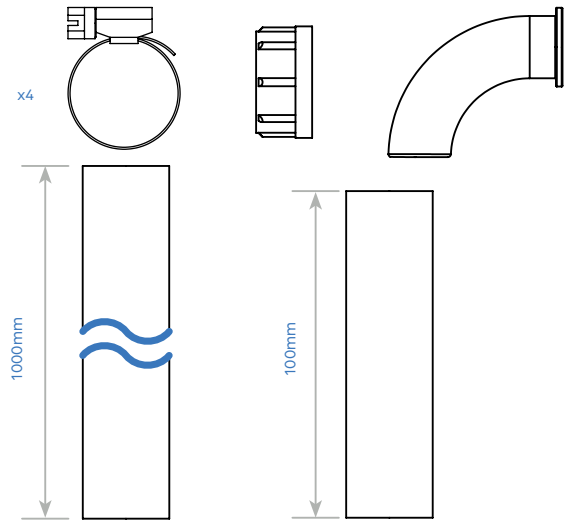

3 Control Hub

- x1 Control Hub
- x4 Screws
- x4 Wall plugs
- x1 OWA 60W-24V Power Supply

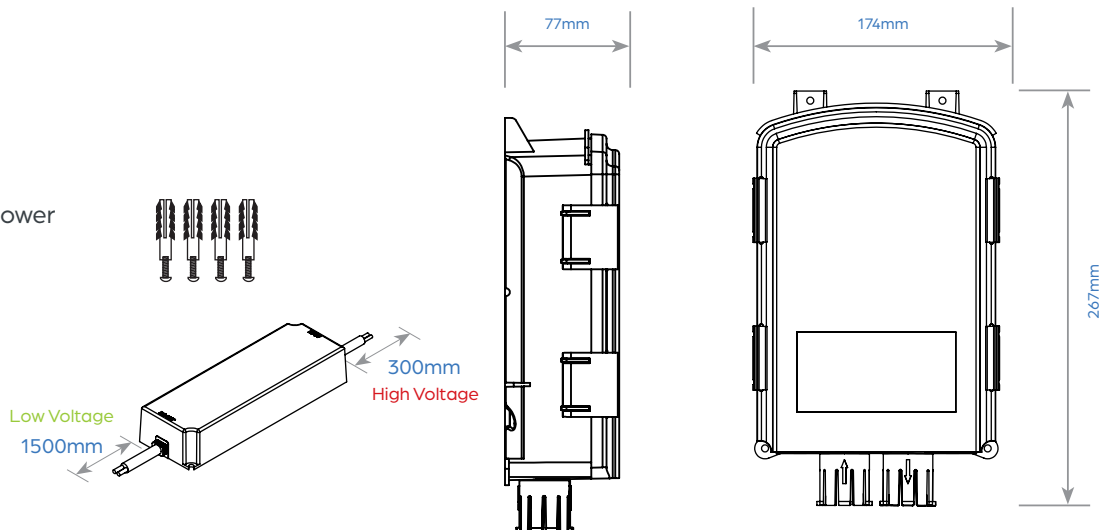

Siting the Shower

Flex Head 91017100

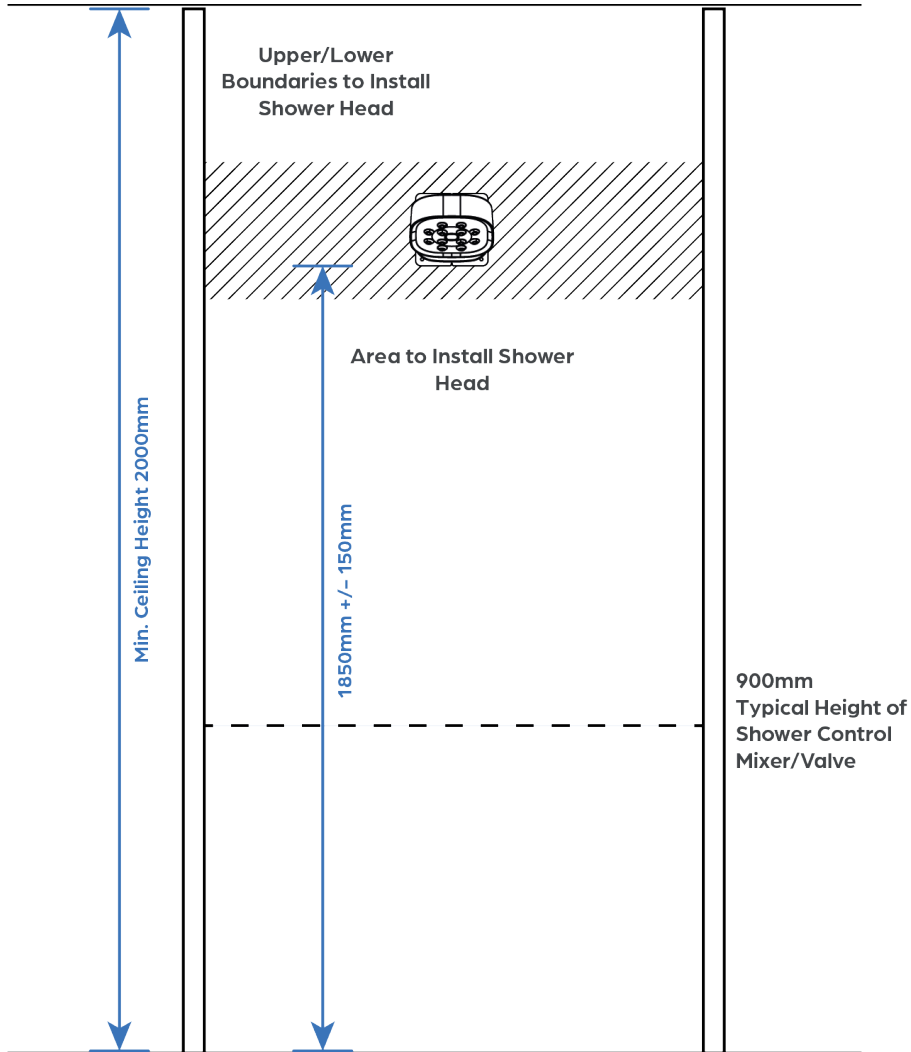

Installation should be completed to suit the user's requirements, with Flex Head being situated within reach of user.



M3 Pozzi Screwdriver



Pencil



Drill with Drillbit for Screw Sockets



Wrench

Tools needed for the job

Warning!

- The Control Hub should not be installed in an outdoor environment, including sheltered areas.
- Do not install the power supply directly beneath the water inlet.
- When the Control Hub is installed, the RCBO switch must be within easy reach.
- Do not use extensions or multiple sockets
- The power supply cable must never be bent or dangerously compressed
- Only use the supplied power supply.
- Two people are required for installation
- Siting of shower based on user and water inlet requirements



Installation

Control Hub



Remember!

Only use the power supply and electrical connections provided.
Always check for hidden pipes + cables before drilling.

1

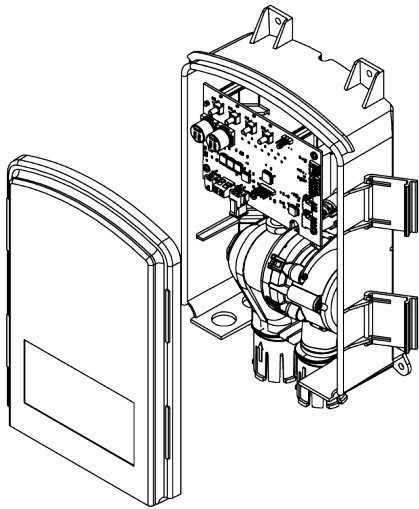

Prepare Control Hub for wall mounting. Ensure Hub Clips are all functional and screw holes are clear.

2

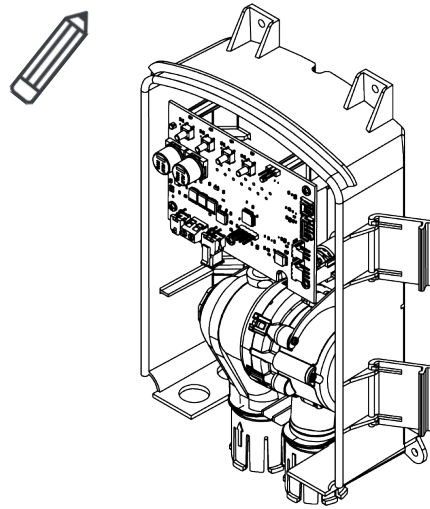

Select the position for the Control Hub referring to the "Siting the Shower" figure on page 7.
Locate the four screw holes and mark onto wall being drilled.

3

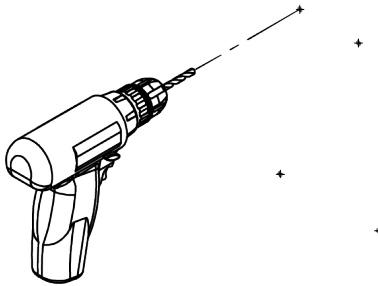

STEP 1

4

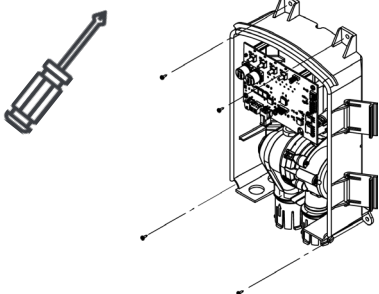

STEP 2

Cover the Control Hub with its lid and secure the fastening clips. Drill the holes for the screws to go into the wall. Screw them into place with the Control Hub mounted on the wall using a screwdriver.

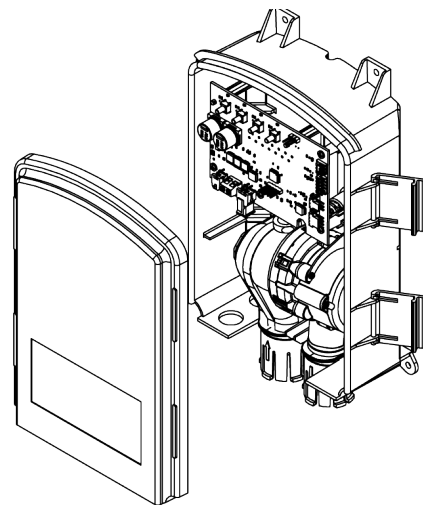

Ensure the electrical installations on page 11 are completed and power is being supplied to the Control Hub PCB, indicated by the LEDs being lit.

Flex Head Installation



Remember!
Read through all instructions before beginning installation.
Always check for hidden pipes + cables before drilling.

1

STEP 1

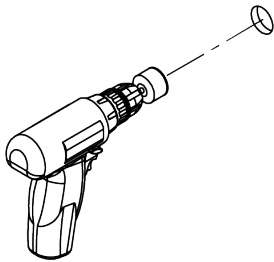
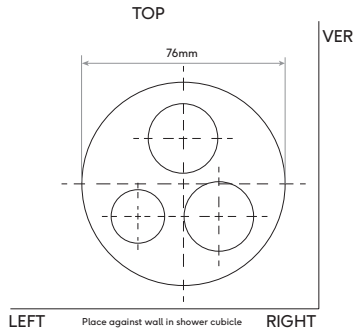

STEP 2

Using the provided template in this booklet, mark the position for the shower head on the cubicle wall and drill the hole making sure the hole saw is the correct size.

2

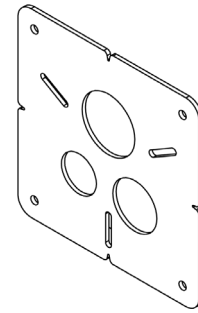

Place the pipe spacer onto the void wall and secure using the screws supplied. Make sure the spacer is centered by using the viewing windows in the spacer.

3

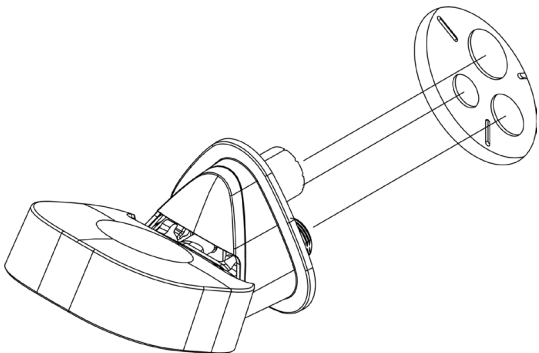

Position shower head onto cubicle wall inserting pipe stubs through the wall into the holes of the spacer, being careful not to damage the pipe threads.

4

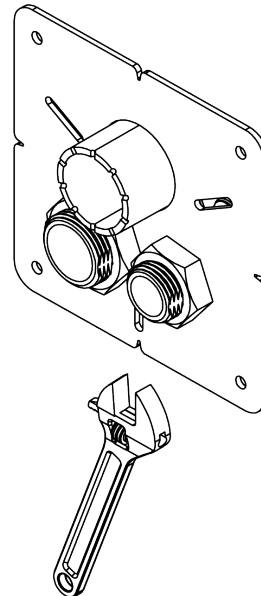

Secure using the correct flange nuts supplied making sure not to over-tighten.

Flex Head Installation



Remember!

Before connecting hoses flush water inlet pipes with roughly 12 litres worth of water to reduce risk of blockage from debris in pipes.

1

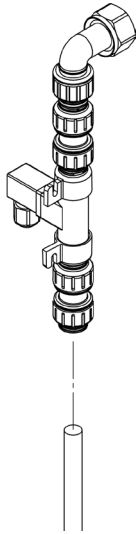

Attach the remote flow sensor assembly to the water inlet pipe by push fit, ensuring the water pipe is isolated first. IRN R008: The flow sensor is to be installed where light is excluded.

2

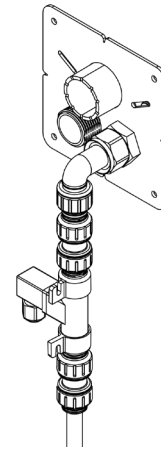

Attach the remote flow sensor assembly to the water inlet in the rear of the shower head backplate.

3

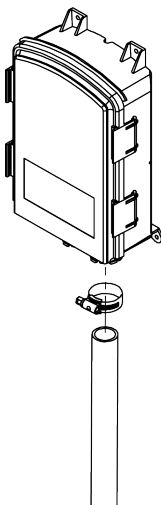

Attach air supply hose to the outlet air adapter on the Control Hub. Tighten using a jubilee clip (supplied) with a screwdriver. Attach air inlet hose to the inlet air adapter on the Control Hub. Tighten using a jubilee clip (supplied) with a screwdriver. Ensure hose connections are airtight. This can be done when first running the shower.

4

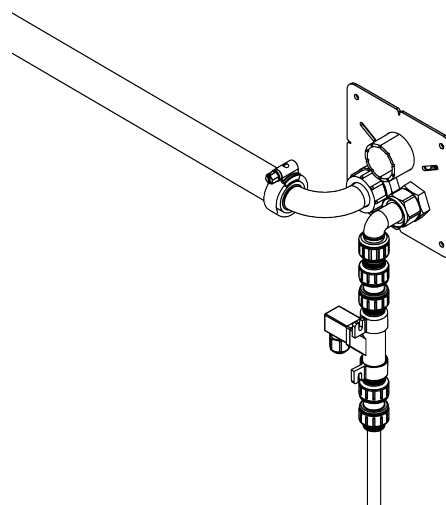

Use the elbow connector and jubilee clip to connect the air outlet hose to the shower head backplate. If air recirculation is suitable, attach air return hose with remaining two jubilee clips.

Electrical Installation

This shower requires a 230–240 VAC, 47 ~ 63Hz single phase supply. A single 3 Amp switched fused spur should be used for each Panel. Up to 12 Kelda showers can run from a single 32A 30mA RCBO.

Before connecting to power supply, make sure that the mains terminal is able to sustain 240V and 3A. All electrical installation to be carried out by an approved electrician in accordance with Part "P" U.K. Building Regulations and to the latest IEEE standards, or the appropriate regulations in the country of installation.

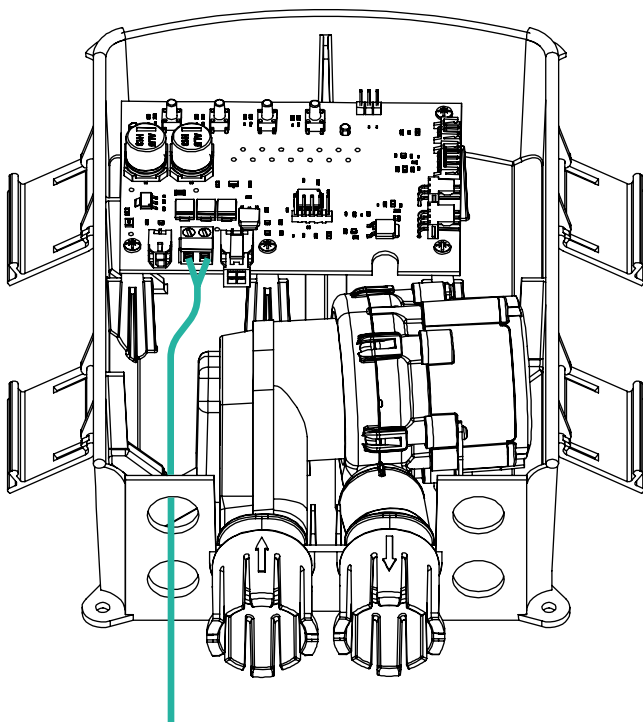
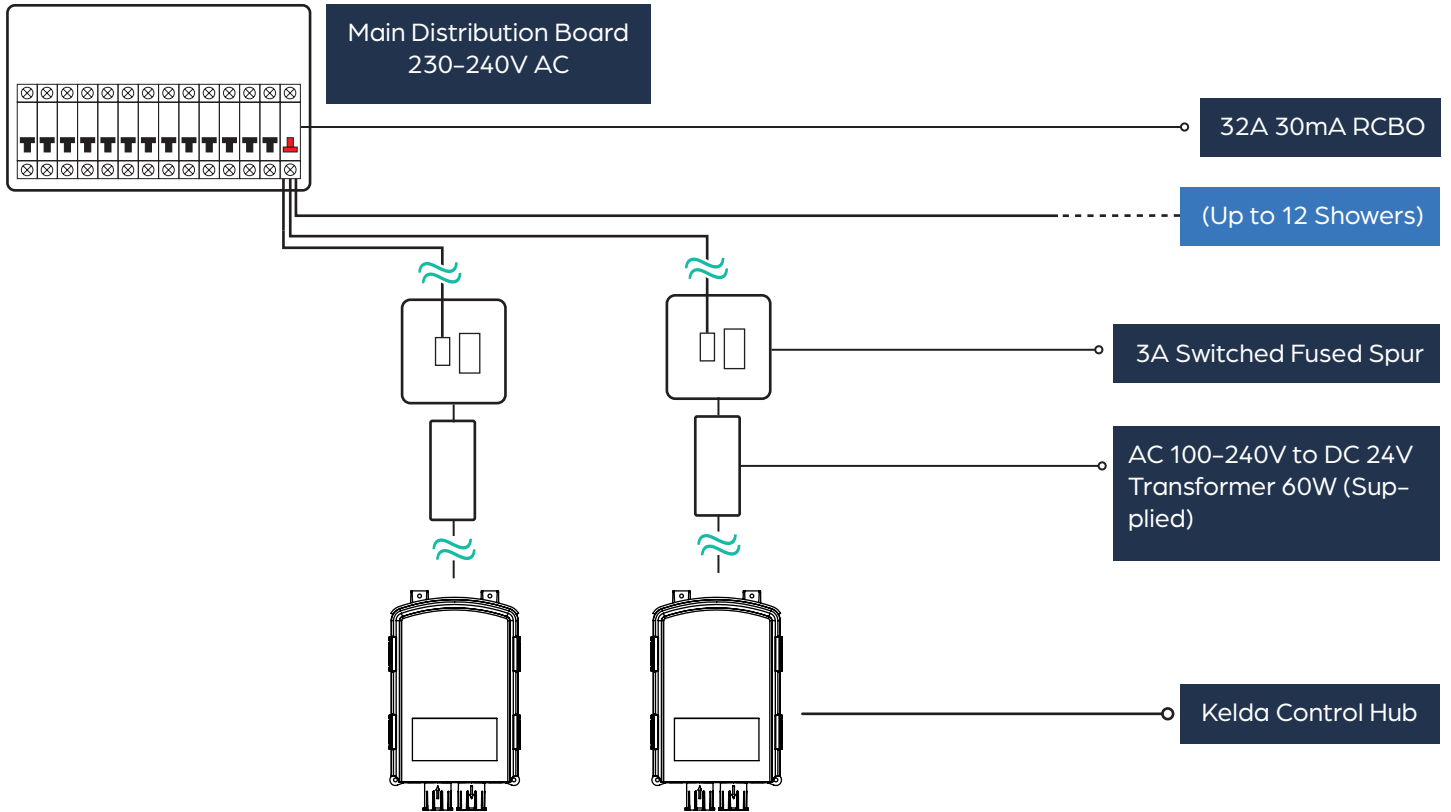

Electrical Connection

1. Thread the power supply cable through the 16mm cable gland in the bottom left of the Control Hub.
2. Connect the cable to the 24V power terminal shown. (Polarity of connections is not important)
3. Using a 3mm flat screwdriver, tighten the connections down and tighten gland nut onto cable

Factory Settings

Air Volume

Your Kelda panel shower will have a different fan speed setting depending on what shower head and water flow rate your product has. This will be set at the factory.

The hub will automatically adjust fan speed to match minor changes in flow rate which may result from changes in water pressure.

However the fan speed can be manually changed if for example the flow regulator is changed to a different value or for other site specific reasons.

Changing the Fan Speed (6 settings)

1. The panel fan settings are pre-set by the factory.
2. To change the fan speed settings, press 'FAN' button once. (There are 6 speed settings: 1-6)
3. To display current fan speed set, press and hold 'FAN' button for 2 seconds. The number of LED flashes corresponds to the speed setting selected.

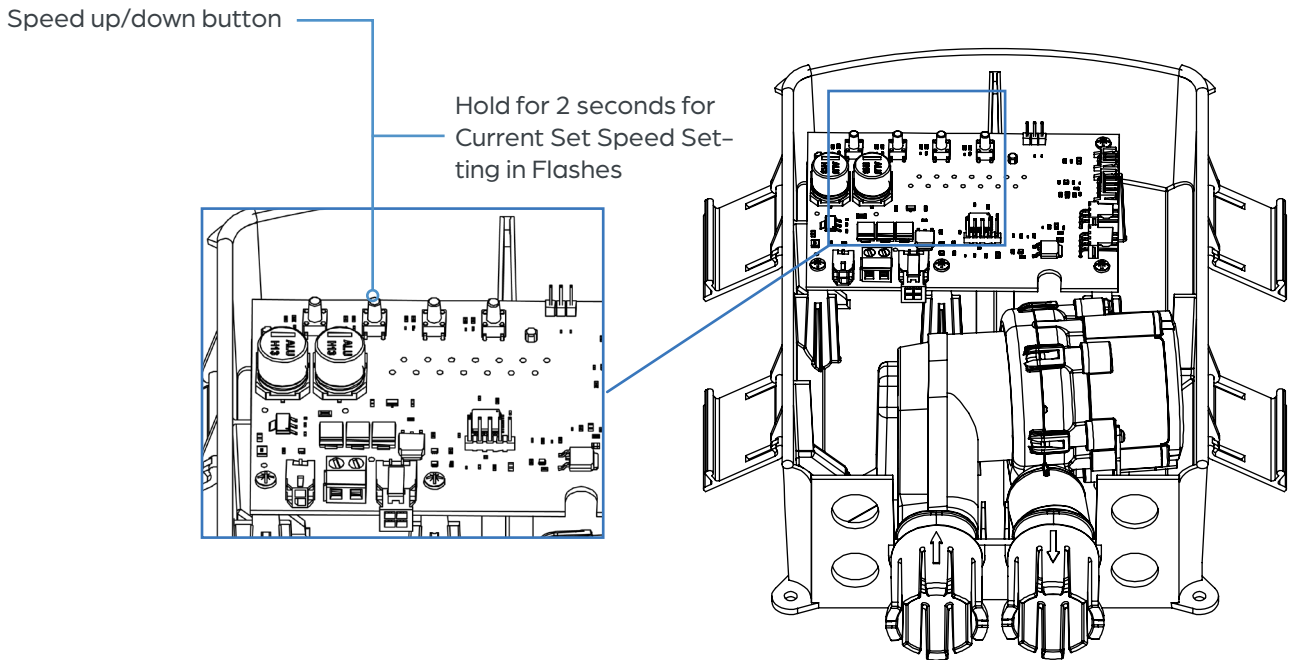

Fan Mode Settings

	Fan Mode	LPM
Dynamic	1	4-6
Dynamic	2	4-6
Dynamic	3	4-6
Static	4	4
Static	5	5
Static	6	6

Dynamic = Flow Sensor Present (93007100, 93008100, 93009100, 93010100)

Static = Time Flow variants (Solenoid Operated) (93011100, 93003100, 93004100)

1. Factory setting is Fan Mode 3 for all TMV Variants
2. Fan Modes 1 and 2 can be used to fine tune performance if necessary
3. If changed, the new Fan Mode remains as default, even after the power has been cycled.

Factory Settings

Air Overrun Function

The system has an air overrun function which allows the air to continue to operate for approximately 1 second after the water flow stops. This function purges the water from the shower head, reducing the build up of lime-scale.

Fan Test Function

Press and hold 'TMR' button for more than 5 seconds to run the fan independently of full shower operation.

Fan Overheat Protection

In the unlikely event of the fan overheating from being jammed with debris or being continuously run in a hot environment, then a protection mode will be triggered. The fan will return to normal operation once debris is cleared or temperature has reduced to sufficient level.

Troubleshooting

Symptom	Likely cause	Action/Remedy
System does not operate fully (reduced or no water flow):	Hot or cold water supply isolation valve closed	Check and open valve
	Debris has caused blockage in mixer	Isolate mixer and service strainers and cartridge see mixer instructions to service
	Pressure difference between hot and cold supplies is too high	Adjust screws on mixer to balance. Or fit pressure reducer on high pressure supply.
Water flows from shower head but no air:	Shower mixer/valve not functioning.	Check valve, replace if necessary.
	Does the fan run?	if so check seal of air hose connections and that hose is kink free.
	Is the LED on the front of the Control Hub illuminated?	If no check electricity supply
		Conduct hard reset by switching off electrical supply and waiting 10 seconds before turning on.
	Debris in fan	Clear any debris from fan and follow Fan Test Function p.12.
		If fan runs then check flow sensor is not jammed or faulty.
Temperature fluctuating:	Thermostatic control/Boiler issue.	Check thermostatic mixer valve/boiler for an issue, call a specialist if necessary.
Poor/no water flow:	Blocked water filter/strainer.	Isolate water supply and service strainers in mixer or group mixer.
Water flow too strong:	Flow restrictor not installed.	Check if the flow restrictor is properly installed (in the back of the head).

Operation

1. Turn on the water isolation valve.
2. Turn on the electricity supply.
3. Check the Control Hub for power. (The LEDs inside the Hub should be illuminated).
4. The Kelda Showers system operates by detecting water flow. It starts when water flow is detected and stops when the water flow ceases.
5. Open the shower mixer/valve. Water should start to flow from the shower head, followed very quickly by the air flow. Once the water valve times out, the water will cease to flow and the air will continue to operate briefly. This purges water from the shower head.

Congratulations, you're now ready to experience the greenest shower in the world and start saving water and energy costs!

Maintenance

Kelda Showers products are precision-engineered and should give continued superior and safe performance, provided:

1. They are installed, commissioned, operated and maintained in accordance with this installation guide.
2. Periodic attention is given as necessary to maintain the product in good functional order.

Guidelines for frequency are given below. Maintenance must be carried out in accordance with these instructions, and must be conducted by designated, qualified and competent personnel. Components are precision-made, so care must be taken during maintenance to avoid damage.

Daily/Weekly Hygiene

External surfaces of the shower head may be wiped clean with a soft cloth and if necessary, a mild detergent or soap solution can be used.

Quarterly Hygiene*

Shower heads to be dismantled to clean, de-scale and sanitise removable parts, heads and inserts. Please see instructions for dismantling and reassembling head for cleaning.

*If showers are in a high usage area or where the water feed to showers has high hardness levels this will be required more frequently.

Bi-Annual Visual & Hygiene

Check internal component condition of the shower head and hoses. Inspect for debris, scale deposition, deformation, damage, etc. Maintain or renew if necessary. Please see Instructions for cleaning and disinfection of air hose and Control Hub

Instructions for Dismantling and Reassembling Head for Cleaning

1. Remove the fascia plate screw cap with a small flat head screwdriver (1)
2. Remove centre screw using a pozidriv PZ2 ensuring the fascia plate (2) and atomisation engine (3) are held until screw removed.
3. Slowly lower fascia plate and atomisation engine.
4. Carefully detach the rubber hose from the water chamber (4) ensuring not to remove the hose from the other end.
5. Carry out clean, de-scale and sanitisation of shower head components in line with our maintenance guidelines.
6. To reassemble, follow steps in reverse.

Flex Head

81003100

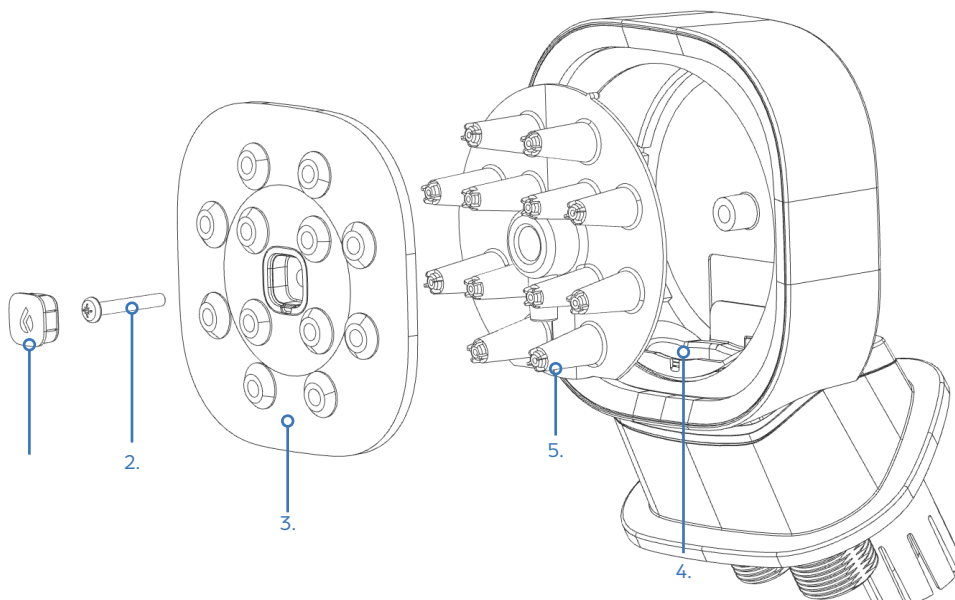

Maintenance

Cleaning and Disinfection of Air Hoses

- Isolate power supply to Control Hub.
- Remove air supply hose by loosening jubilee clip and gently easing hose off the air outlet adapter.
- Remove 90 degrees elbow connector by unscrewing $\frac{3}{4}$ " Air nut and loosening the jubilee clip and gently pulling apart.
- Remove air return hose by loosening jubilee clips and gently easing hose off the air inlet adapter and backplate vent.
- Put aside all hose clips in a safe place.
- Whilst wearing the correct safety equipment, dip hoses into a disinfectant solution so all the hoses are submerged.
- Remove from solution and clean out hoses using a pipe cleaning brush.
- Dip hoses into disinfectant solution and flush through, continue this until hoses are clean.
- Once hoses are clean, flush hoses through with fresh water.
- Shake out any excess water and wipe dry.
- Replace air supply hose by gently inserting into air outlet adapter and tightening jubilee clip.
- Replace 90 degrees elbow connector by gently inserting into hose, screwing $\frac{3}{4}$ " Air nut onto shower head hose pipes and tightening jubilee clip.
- Repeat steps for air return hose in reverse for air recirculation installations.
- Reinststate power supply to Control Hub.
- Run shower for 2-3 minutes to dry any moisture in the hoses.



Warning!

During regular cleaning of the shower area, do not direct a water hose at the shower head while the shower is functioning. Many household and industrial cleaning products contain mild abrasives and chemical concentrates and should not be used on this product.

Spare Parts

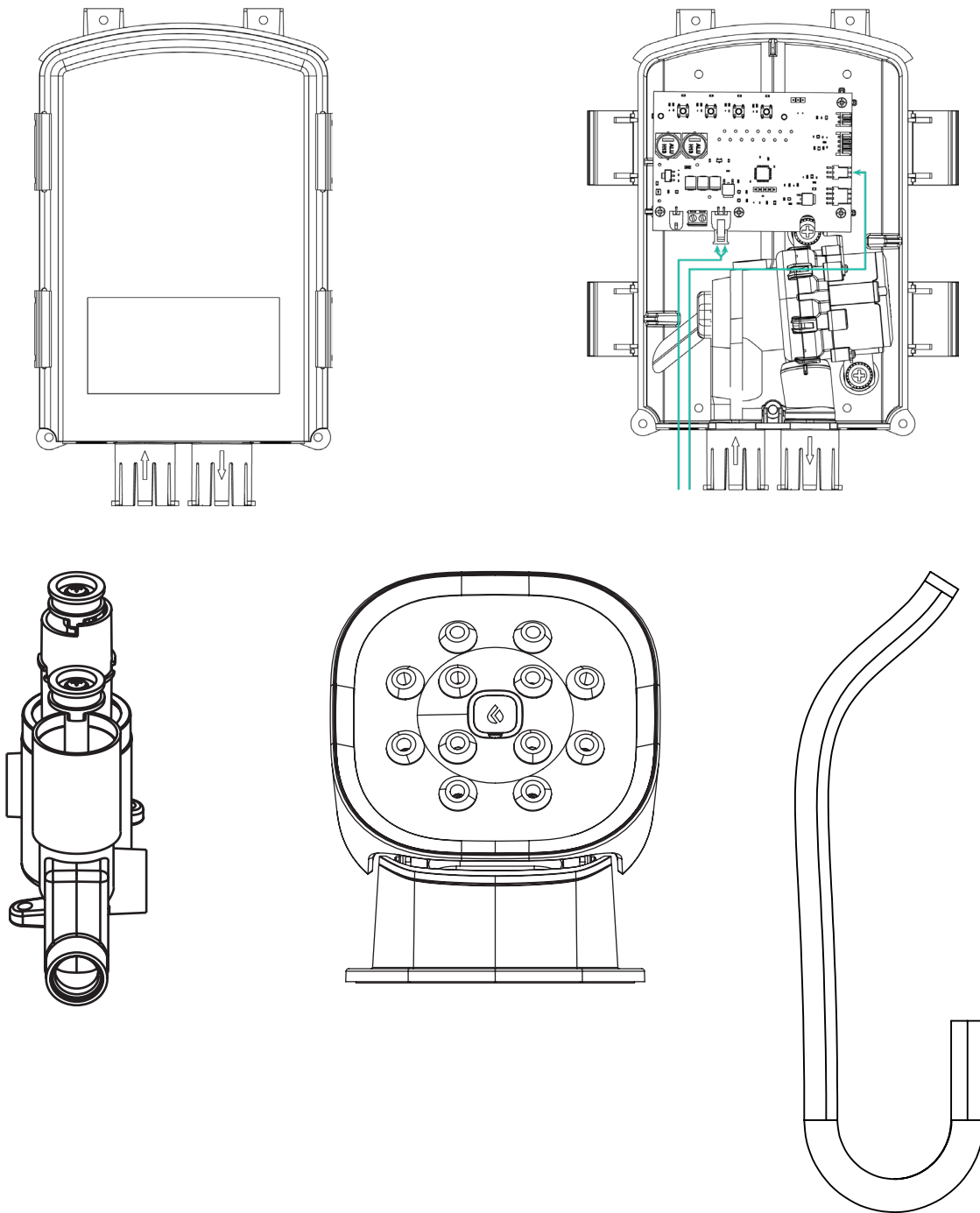

No.	Part No.	Description	Parts List
1	79109	P23 Control Hub replacement front cover	Front cover
2	60010, 79054, 79076, 79108, 79110	P23 Control Hub replacement complete unit	PCB, Fan Duct, Backplate Casing, Lid Clips
3	35017	19mm 1000mm Air hose	19mm 1000mm Air Hose
4	32008/32009	TMV2 Mixer Valve	TMV2 Mixer Valve
5	81003100	Flex AV Shower Head	Shower Head, Face Plate, Nozzles, Fixing Parts

Customer Care

Guarantee

Kelda Showers guarantees this product against any defect in materials or workmanship for the period of two years from the date of purchase. To be covered by this guarantee, service work must only be undertaken by Kelda Showers or by its approved agents.

Not Covered by this Guarantee

Damage or defects arising from incorrect installation, improper use or failure to maintain in accordance with the instructions in this product manual, including the build-up of limescale. Defects or damage if the product is taken apart, repaired or modified by a person not authorised by Kelda Showers or by their approved agents.

After-Sales Service

Our fully trained staff are ready to provide assistance, should you experience any difficulty operating your Kelda Showers equipment.

Spare Parts

All functional parts of Kelda Showers products are available.

All spares are guaranteed for 12 months from date of purchase.

Spares that have been supplied directly from us can be returned within one month from date of purchase, providing that they are in good order and the packaging is unopened.

Note: returned spares will be subject to a 15% restocking charge and authorisation must be obtained from Kelda Showers before return.

Customer Care Policy

If within a short space of time of installation the product does not function correctly, first check with the operation and maintenance advice provided in this installation guide to see if the difficulty can be overcome. Failing this, contact your installer to make sure that the product has been installed and commissioned in full accord with our detailed installation instructions. If this does not resolve the difficulty, please contact Kelda Showers, who will give you every assistance.

Warning!



- The Control Hub should not be installed in an outdoor environment, including sheltered areas,
- When the control box module is installed, the mains socket must be within easy reach
- Do not use extensions or multiple sockets
- The power supply cable must never be bent or dangerously compressed
- Only the supplied power supply should be used with the product.

Patents:

	1692638PP/CN	1714634PP/CN
Patents granted and pending:	1692638PP/US	1714634PP/US
2454228	1692638P/HK	2612790
9173809	1875355D/GB	1850858P/PCT
2675568	1875355D/CTM	
ZL201280009000.7	4135905	
4146403	1714634P/HK	

Installation Template

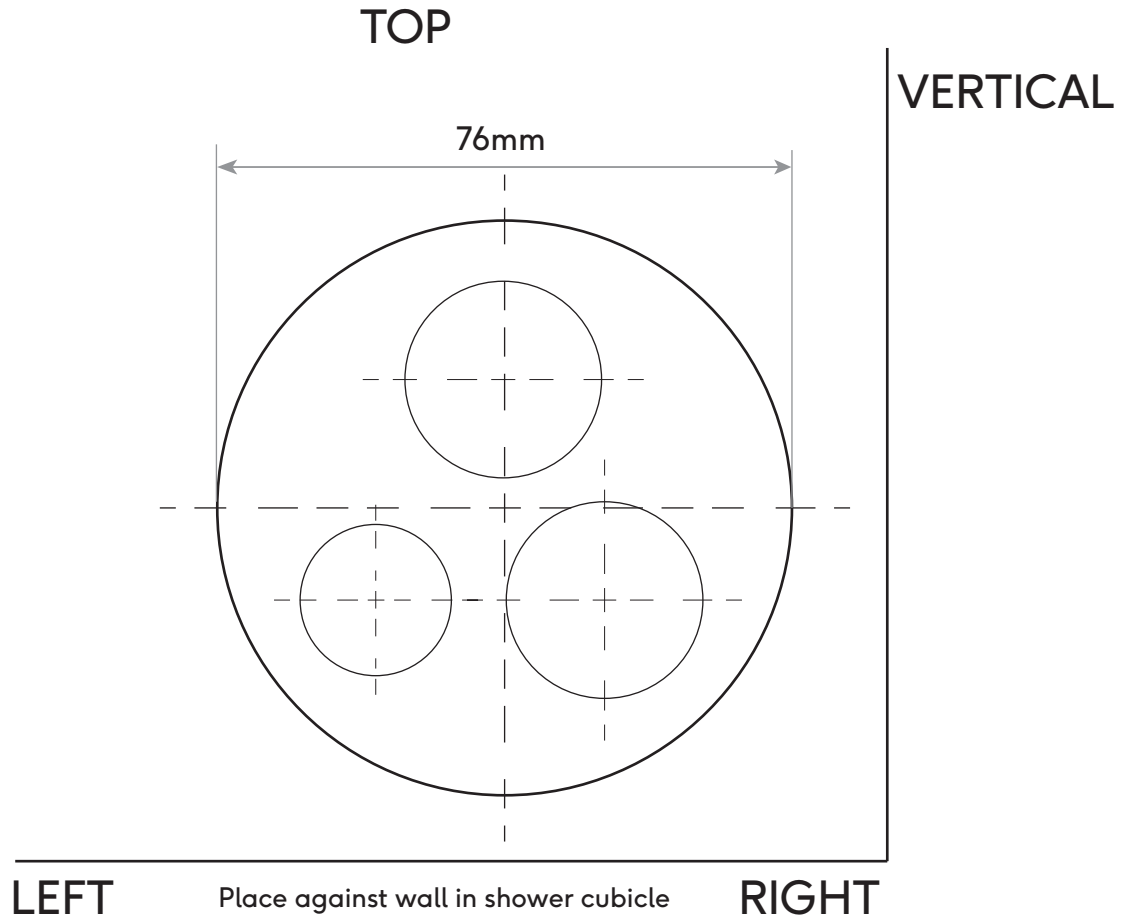

Flex & Fixed AV Shower head

91017100 & 91016100



UK HEAD OFFICE

Unit 11, Brickfield Trading Estate, Chandler's Ford, Eastleigh,
SO53 4DR, UK

Tel: +44 (0)2381 290640

Web: www.keldashowers.com



DISPOSAL

Do not dispose of with household waste. Please recycle where facilities exist.
Check with your local authority for recycling advice.